

Part Number:

1990218
1990236

Models:

Himalayan
Continental GT 650 (2018 onwards)
Interceptor INT 650 (2018 onwards)
INT 650 (US Only) (2018 onwards)
Classic 350 (2021 onwards)
Bullet 350 (2023 onwards)
Guerrilla 450
Meteor 350 (2020 onwards)
Scram 411
Hunter 350
Super Meteor
Shotgun 650

WARNING: Royal Enfield genuine accessories are designed to fit only the specific Royal Enfield motorcycle(s) that are specified above. They should not be fitted to any other type of motorcycle. Pay particular attention to the warnings and cautions contained in this instruction, failure to do so may result in an incorrect installation of the accessory which could result in an unsafe riding condition and possible accident. If in any doubt always seek the help from your authorised Royal Enfield dealer.

WARNING: Before starting any accessory kit installation ensure the motorcycle is supported in a stable condition. Failure to support the motorcycle correctly could lead to motorcycle damage or personal injury.

WARNING: All fixings must be tightened to the torque values specified in this instruction. Failure to tighten fixings to the correct torque could result in an unsafe riding condition and possible accident.

CAUTION: Care should be taken when fitting any accessory kit. Incorrect handling kit components or the use of incorrect tools could lead to component or motorcycle damage.

NOTE: The content of this instruction is subject to change at any time without notice or liability. Royal Enfield reserves the right to revise the information presented at any time.

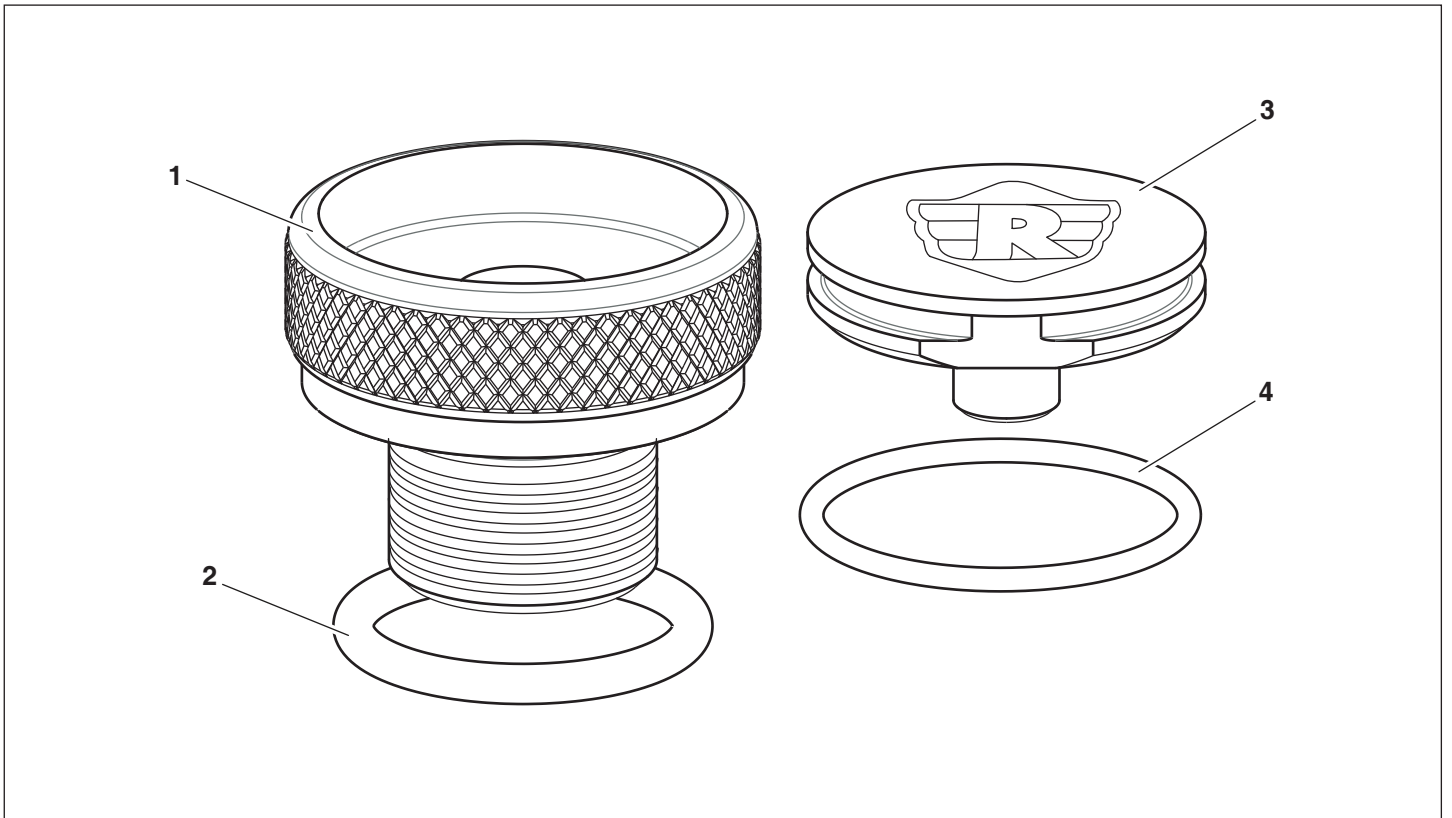

Item	Description	Qty
1	Oil filler cap body	1
2	O-ring, oil filler body	1
3	Logo insert	1
4	O-ring, logo insert	1

WARNING: If the engine has recently been running the engine and exhaust system will be hot. Before working near to the engine or exhaust system always allow time for the engine and exhaust system to cool. Touching any part of a hot engine or exhaust system will cause burn injuries.

1 Remove the original oil filler cap (1) from the engine crankcase by turning the cap by hand in an anti-clockwise direction. Retain the original oil filler cap for reuse if the accessory oil filler cap is removed.

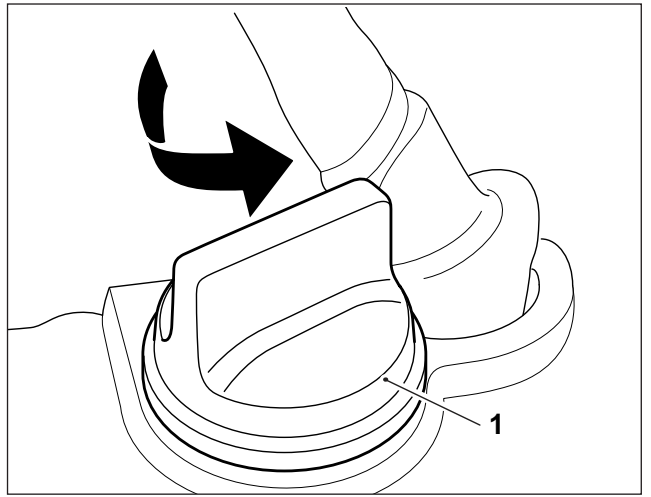

2 Fit the O ring seal (1) from the kit on to the accessory oil filler cap body (2) as shown. Ensure the O ring seal locates correctly in the machined groove (3) in the oil filler cap body.

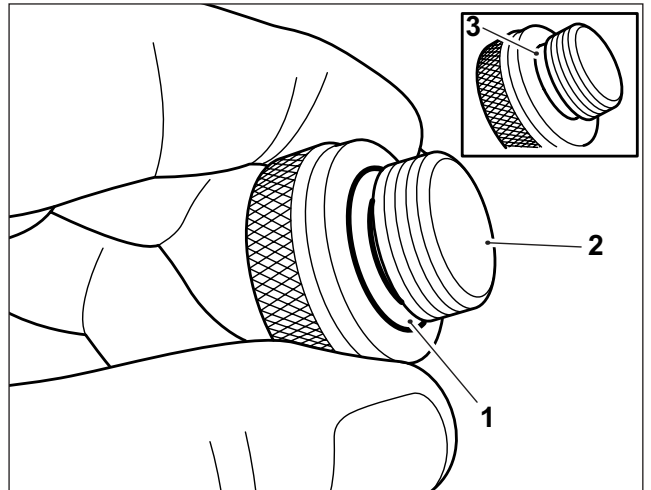

3 Clean the area around the oil filler aperture (1) in the crankcase removing any debris or corrosion. Care should be taken to ensure debris is not allowed to enter the oil filler aperture during the cleaning operation.

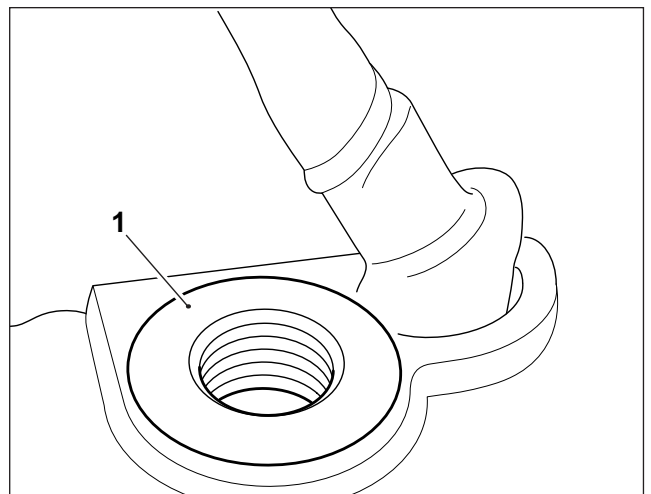

4 Fit the accessory oil filler cap body (1) in to the engine crankcase (2) and turn the oil filler cap body in a clockwise direction by hand until fully engaged in to the crankcase.

CAUTION: The accessory oil filler cap body must only be fitted in to the engine crankcase and tightened by hand. Do not use tools of any description to tighten the accessory oil filler cap body. Using any form of tool to tighten the oil filler cap body may result in damage.

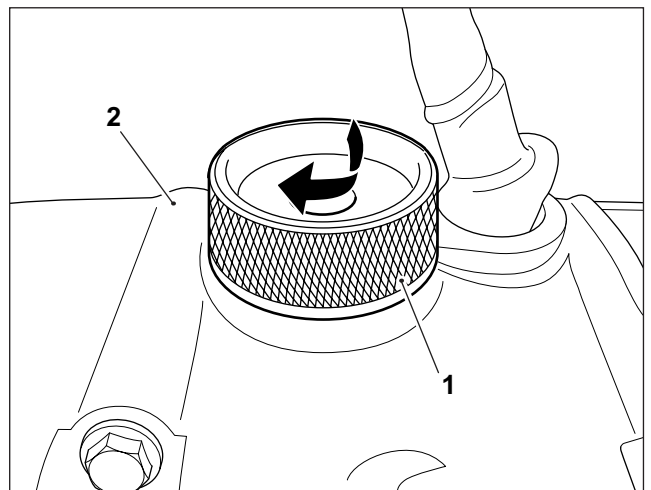

5 Collect the logo insert (1) from the kit and check the O ring seal (2) is correctly located in the insert

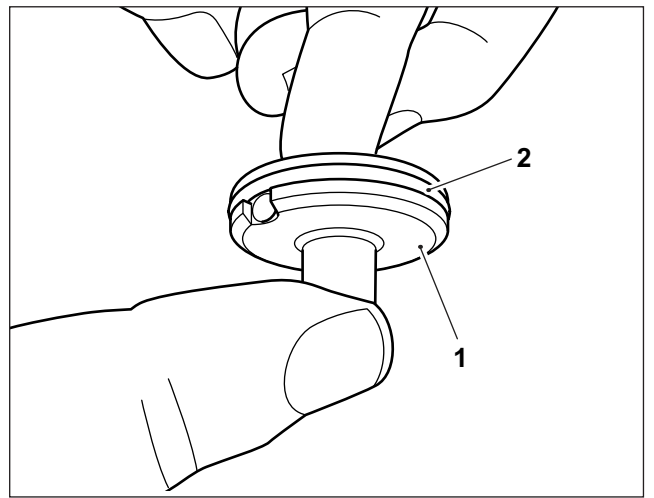

6 With the oil filler cap body (1) secured in the engine crankcase loosely place the logo insert (2) from the kit in to the oil filler cap body, as shown. Rotate the logo insert to the desired orientation..

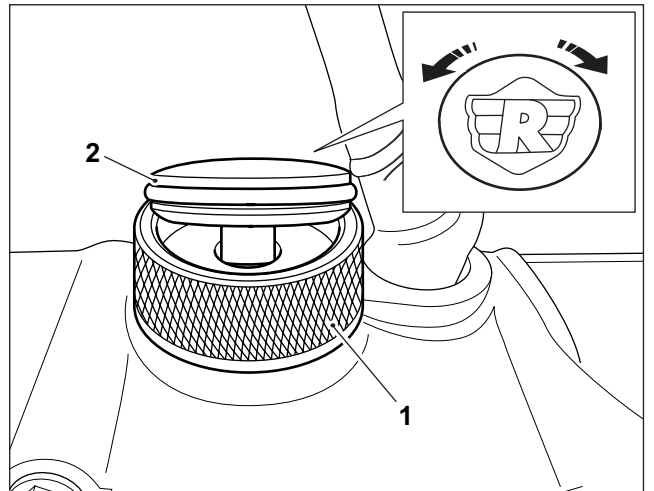

7 With the logo insert (1) in the desired orientation press the insert fully in to the oil filler cap body (2) by hand until the top of the logo insert is level with the top edge of the oil filler cap body.

NOTE: If further adjustment to the orientation of the logo insert is required it is possible to rotate the insert after it has been pressed in to the oil filler cap body.

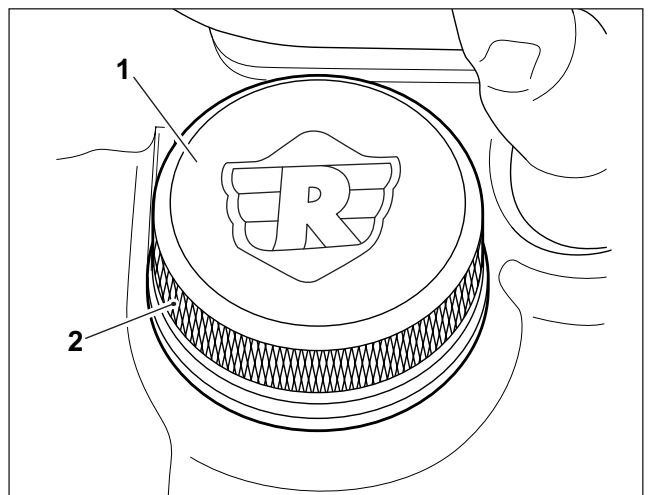

⚠ WARNING: After fitting any genuine Royal Enfield accessory always ride the motorcycle with caution and allow time to become familiar with any change in the motorcycle handling characteristics. Failure to become familiar with any change in the motorcycle handling characteristics may cause the motorcycle to become unstable and result in an accident.