



Part Number:
KXA00437

Models:
Himalayan
(452cc only)

 **WARNING:** Royal Enfield genuine accessories are designed to fit only the specific Royal Enfield motorcycle(s) that are specified above. They should not be fitted to any other type of motorcycle. Pay particular attention to the warnings and cautions contained in this instruction, failure to do so may result in an incorrect installation of the accessory which could result in an unsafe riding condition and possible accident. If in any doubt always seek help from your authorised Royal Enfield dealer.

 **WARNING:** Before starting any accessory kit installation ensure the motorcycle is supported in a stable condition. Failure to support the motorcycle correctly could lead to motorcycle damage or personal injury.

 **WARNING:** All fixings must be tightened to the torque values specified in this instruction. Failure to tighten fixings to the correct torque could result in an unsafe riding condition and possible accident

 **CAUTION:** Care should be taken when fitting any accessory kit. Incorrect handling of kit components or the use of incorrect tools could lead to component or motorcycle damage.

NOTE: The content of this instruction is subject to change at any time without notice or liability. Royal Enfield reserves the right to revise the information presented at any time.

Parts Supplied: KXA00437

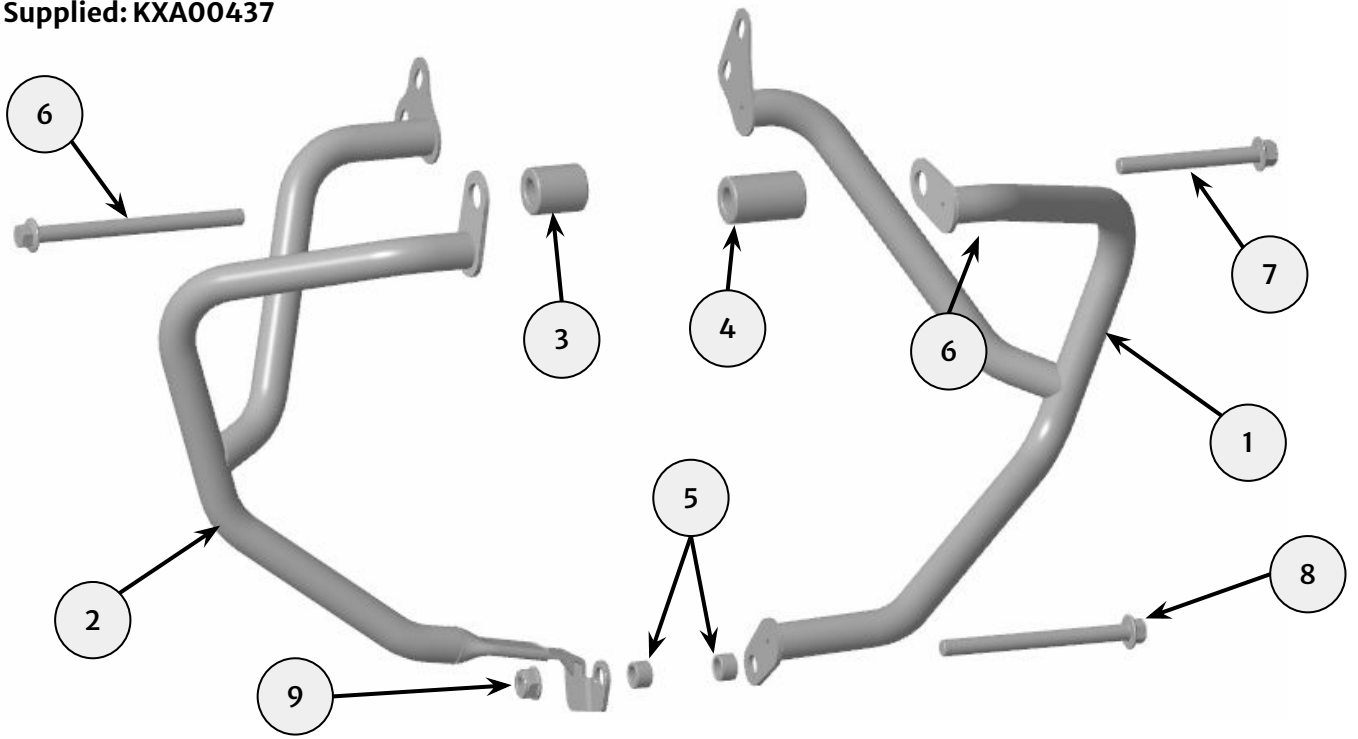

Item	Description	Qty
1	Left hand engine guard	1
2	Right hand engine guard	1
3	Spacer, 32mm	1
4	Spacer, 46mm	1
5	Spacer, 10mm	2
6	Fixing, M10 x 135mm	1
7	Fixing, M10 x 90mm	1
8	Fixing, M10 x 120mm	1
9	Nut, M10	1

1 Remove the original sump guard (1) by removing the two fixings (2). Retain the sump guard and fixings for reuse.



5mm hexagonal bit and ratchet

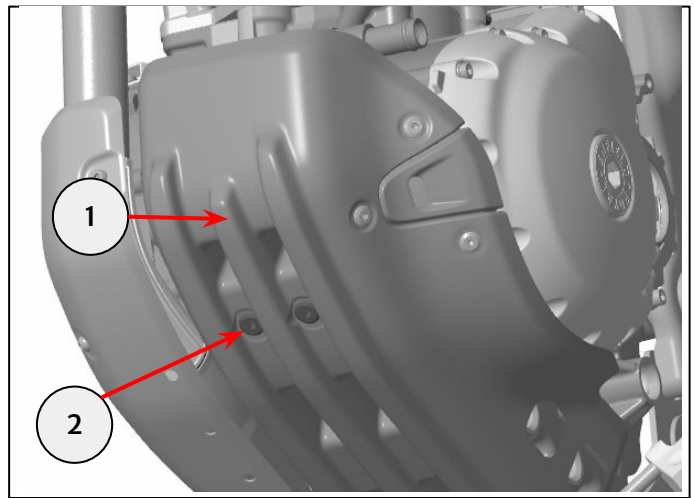

2 Remove the nut (1) and fixing (2) securing the front sump guard bracket (3). Remove the bracket and retain for reuse. Retain the fixings for reuse if the motorcycle is to be returned to its original condition.



14mm socket and ratchet
17mm spanner



WARNING: Assemble the left hand engine guard before assembling the right hand guard to ensure the engine is fully supported throughout.

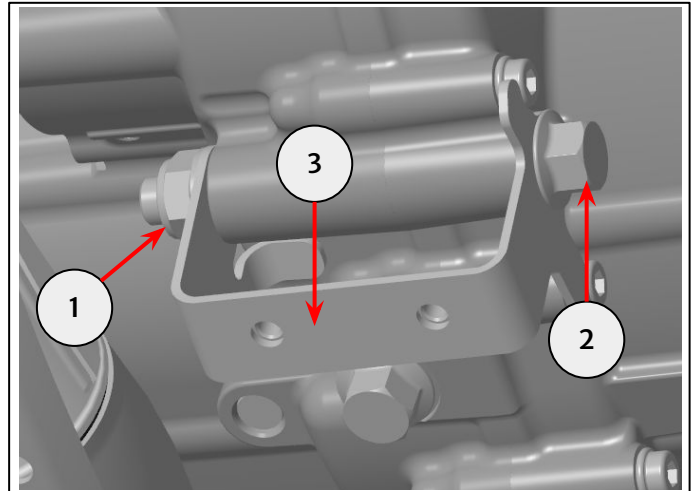

Left hand side

3 Remove the two fixings (1) from the left hand rear cylinder head mount (2) and retain for reuse.



12mm socket and ratchet

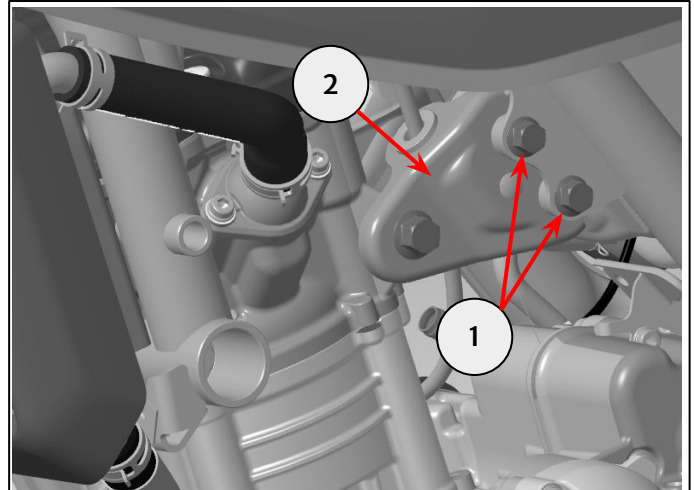

4 Remove the left hand front engine mount fixing (1) and retain for reuse if the motorcycle is to be returned to its original condition.



14mm socket and ratchet

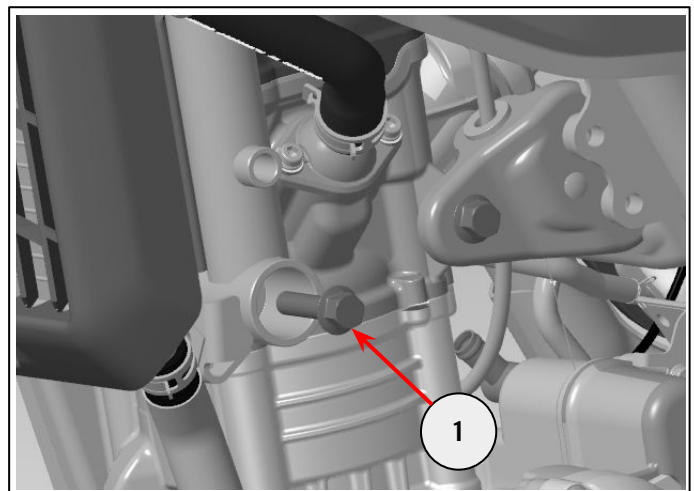

5 Place the 46mm spacer (1) from the kit within the motorcycle frame recess (2).

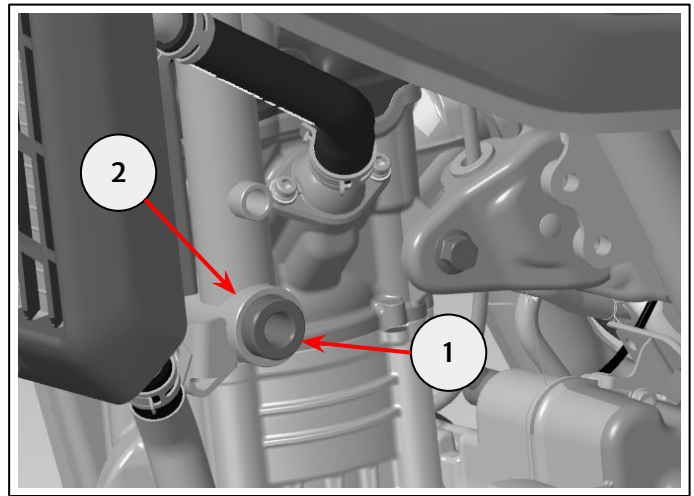

6 Align the left hand engine guard to the motorcycle as shown. Refit the sump guard bracket (1) previously removed in step 2, placing a 10mm spacer (2) from the kit in between the sump guard bracket and engine guard (3). Place the M10 x 120mm fixing (4) from the kit through the mounting hole.

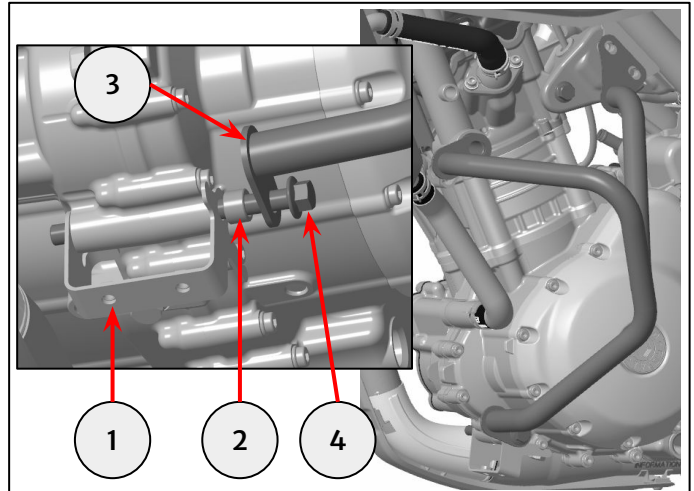

7 Refit the M8 fixings (1) previously removed in step 3 to secure the rear engine guard mount (2) and tighten to 25Nm.

Fit an M10 x 90mm fixing (3) from the kit through the front engine mount (4) and tighten to 45Nm.

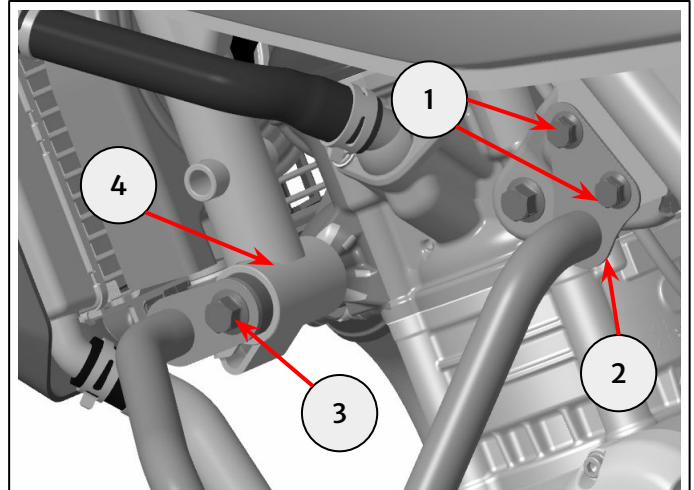

12mm socket and torque wrench
14mm socket and torque wrench

Right hand side

8 Remove the two fixings (1) from the right hand rear cylinder head mount (2) and retain for reuse.



12mm socket and ratchet

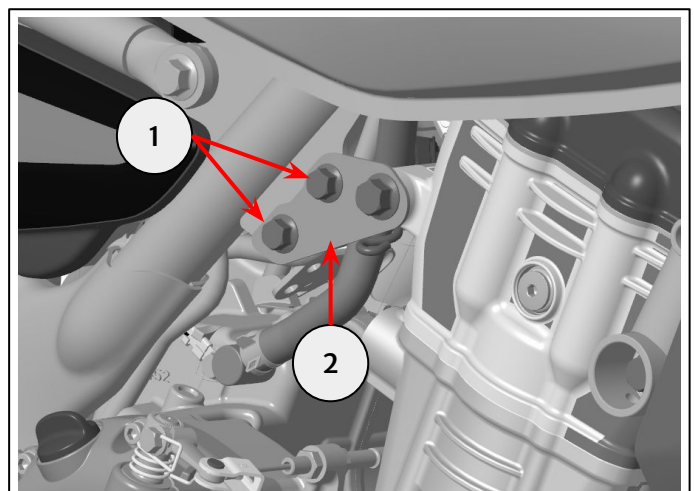

9 Remove the right hand front engine mount fixing (1) and outer washer (2) and retain for reuse if the motorcycle is to be returned to its original condition.

Remove the inner washer (3) and nut (4) and retain for reuse.

	14mm socket and ratchet 17mm spanner
--	---

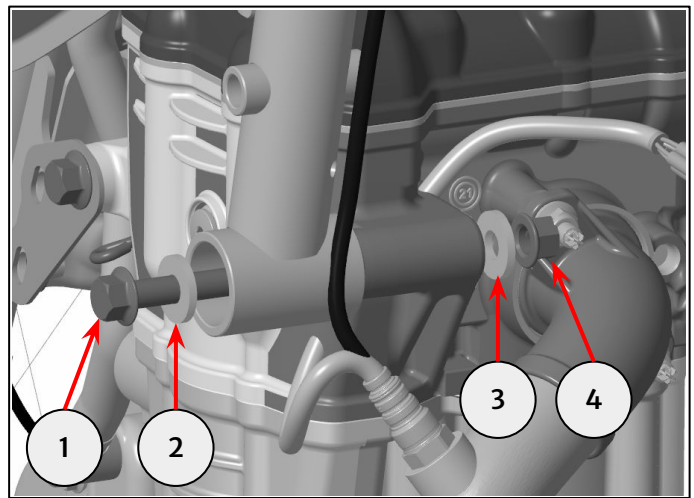

10 Place the 32mm spacer (1) from the kit into the motorcycle frame recess (2).

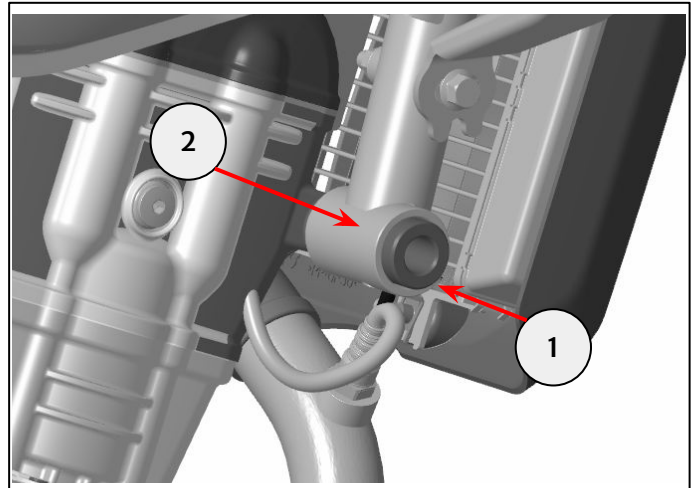

11 Align the right hand engine guard lower mount (1) to the sump guard bracket (2). Place a 10mm spacer (3) from the kit in between the engine guard and bracket. Secure the lower mount with a nut (4) from the kit.

Do not fully tighten at this stage.

	14mm socket and ratchet 17mm spanner
--	---

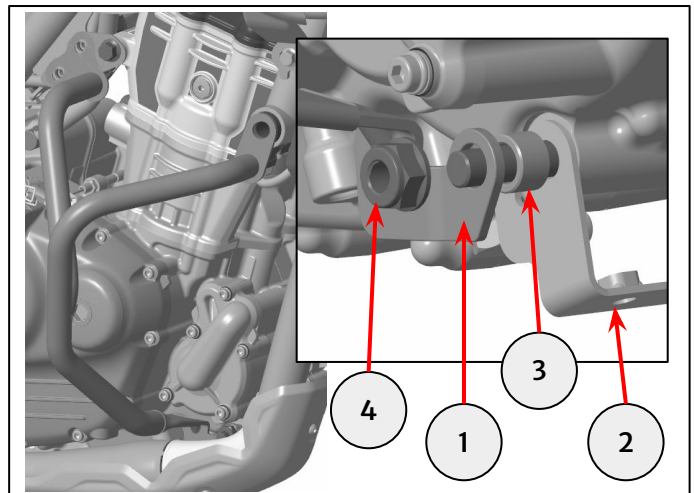

12 Refit the M8 fixings (1) previously removed in step 8 to secure the rear engine guard mount (2).

Tighten fixings to 25Nm.

	12mm socket and torque wrench
--	-------------------------------

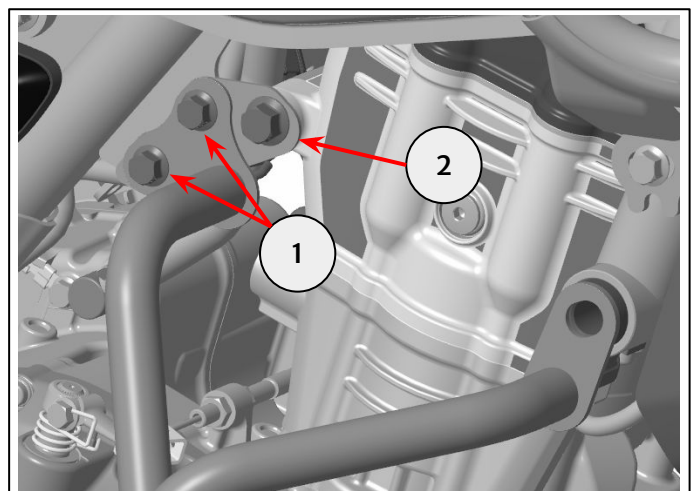

13 Assemble the M10 x 135mm fixing (1) from the kit along with the nut (2) and inner washer (3) previously removed in step 9.

Tighten fixing to **60Nm**.

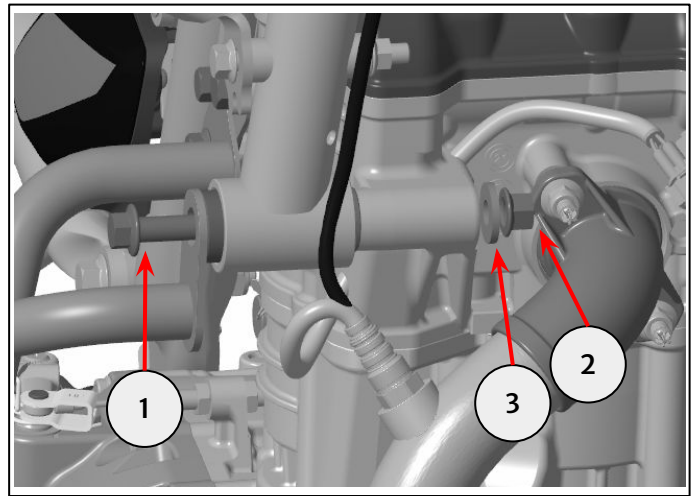
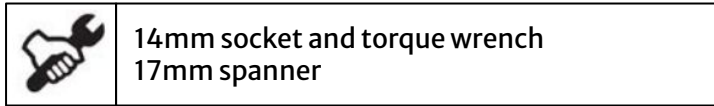

14 Tighten the fixing (1) through the sump guard bracket (2) to **45Nm**.

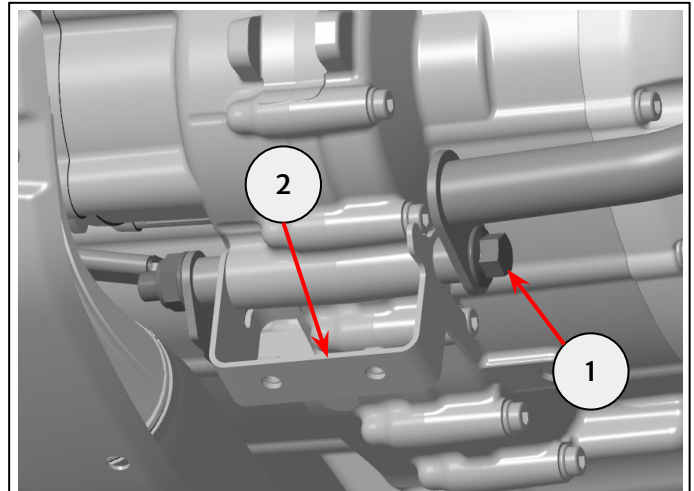
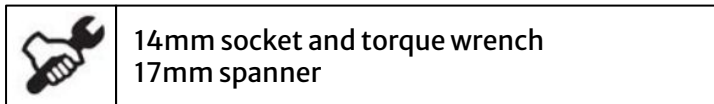

15 Remove the three fixings (1) securing the infill panel (2) from the sump guard (3). Retain the fixings and sump guard for reuse, retain the infill panel reuse if the motorcycle is to be returned to its original condition.

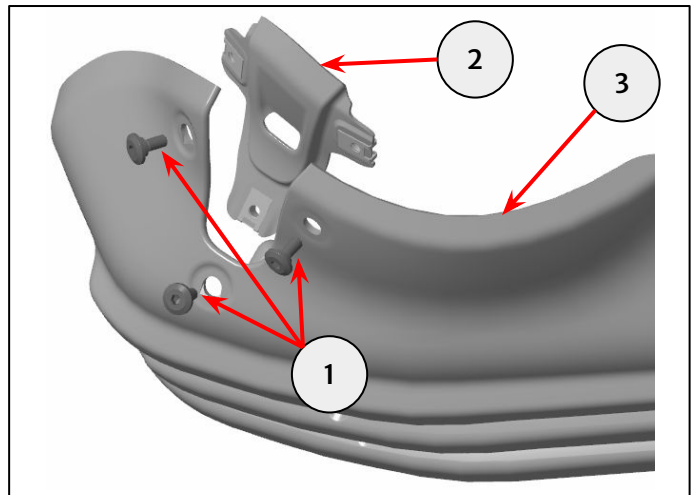
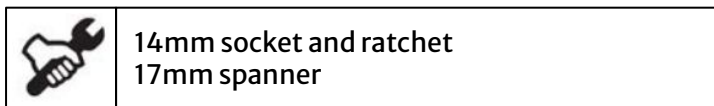

16 Remove the three clip nuts (1) from the infill panel (2) and transfer to the sump guard (3) along with the fixings (4) removed in step 15.

Tighten fixings to **3Nm**.

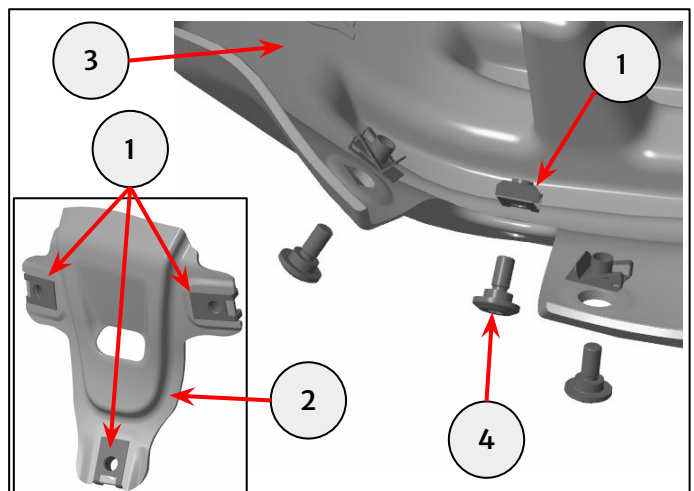
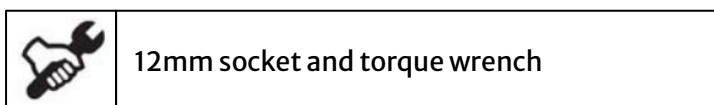

17 Refit the sump guard (1) by sliding the rear edge above the rear bracket (2). Secure the sump guard to the front mounting bracket using the original fixings (3) removed in step 1.

Tighten fixings to **10Nm**.



5mm hexagonal bit and torque wrench

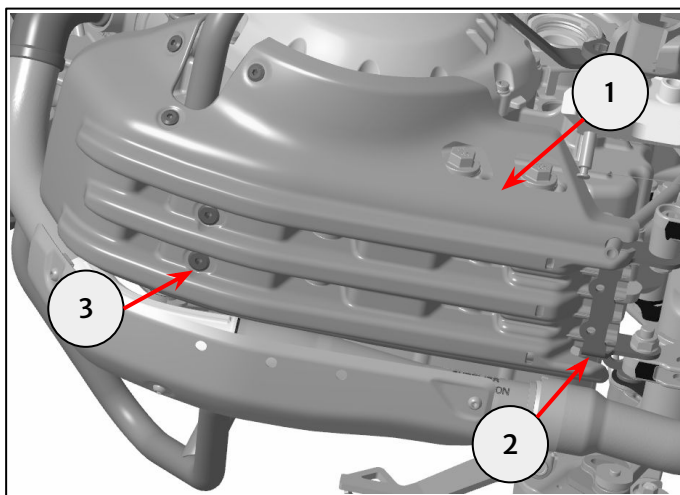

WARNING: After fitting any genuine Royal Enfield accessory always ride the motorcycle with caution and allow time to become familiar with any change in the motorcycle handling characteristics. Failure to become familiar with any change in the motorcycle handling characteristics may cause the motorcycle to become unstable and result in an accident.