

Part Number:
1990401, KXA00277 & KXA00271

Models: SUPER METEOR
SHOTGUN 650

WARNING: Royal Enfield genuine accessories are designed to fit only the specific Royal Enfield motorcycle(s) that are specified above. They should not be fitted to any other type of motorcycle. Pay particular attention to the warnings and cautions contained in this instruction, failure to do so may result in an incorrect installation of the accessory which could result in an unsafe riding condition and possible accident. If in any doubt always seek help from your authorised Royal Enfield dealer.

WARNING: Before starting any accessory kit installation ensure the motorcycle is supported in a stable condition. Failure to support the motorcycle correctly could lead to motorcycle damage or personal injury.

WARNING: All fixings must be tightened to the torque values specified in this instruction. Failure to tighten fixings to the correct torque could result in an unsafe riding condition and possible accident

CAUTION: Care should be taken when fitting any accessory kit. Incorrect handling of kit components or the use of incorrect tools could lead to component or motorcycle damage.

NOTE: The content of this instruction is subject to change at any time without notice or liability. Royal Enfield reserves the right to revise the information presented at any time.

Parts supplied: 1990401

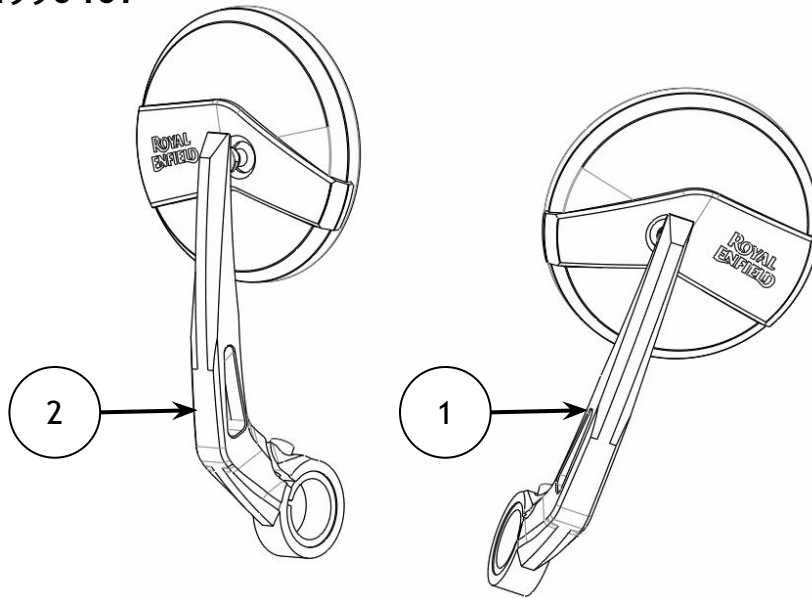

Item	Description	Qty
1	Bar end mirror, left hand	1
2	Bar end mirror, right hand	1

Parts supplied: KXA00277

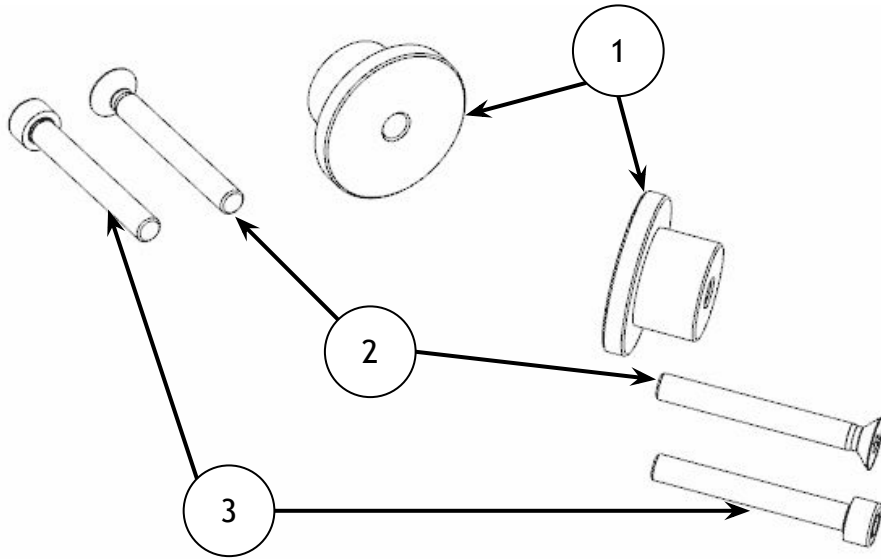

Item	Description	Qty
1	Bar end mirror mounting	2
2	Fixing, CSK M6 x 40mm	2
3	Fixing, CAP M6 x 40mm	2

Parts supplied: KXA00271

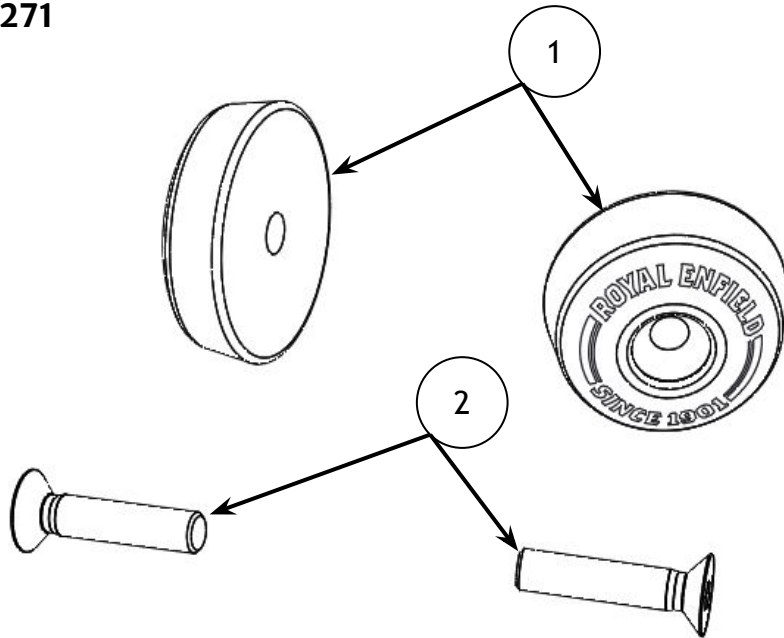

Item	Description	Qty
1	Bar end finisher	2
2	Fixing, M6 x 30mm	2

NOTE: When removing the standard mirrors be advised that the mirror on the left hand side of the handlebars has a right hand thread and the mirror on the right hand side of the handlebars has a left hand thread. Ensure the mirror stem is turned in the correct direction when removing the mirrors from the handlebars.

1 Remove the standard mirrors (1). Retain for reuse if the motorcycle is to be returned to its original condition.

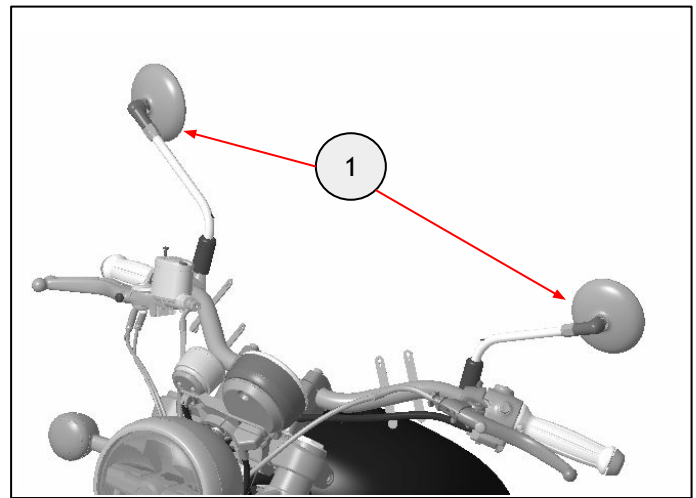
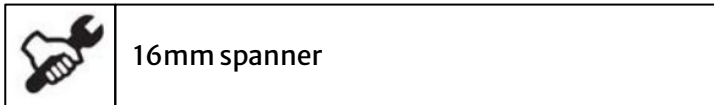

2 Loosen the fixing (1) on the bar end mirror, insert the friction ring (2) into its mounting.

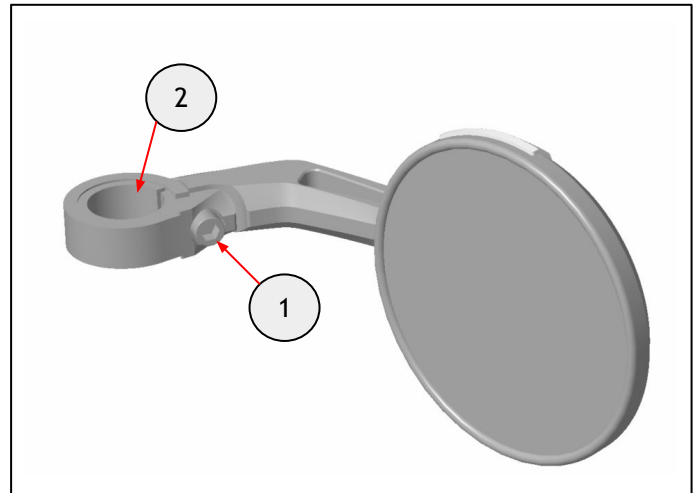
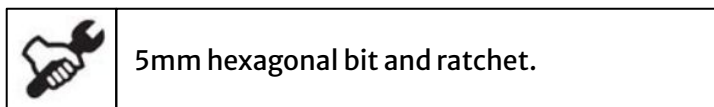

3 Fit the bar end mount (1) into the bar end mirror with the flange head positioned away from the logo (2).

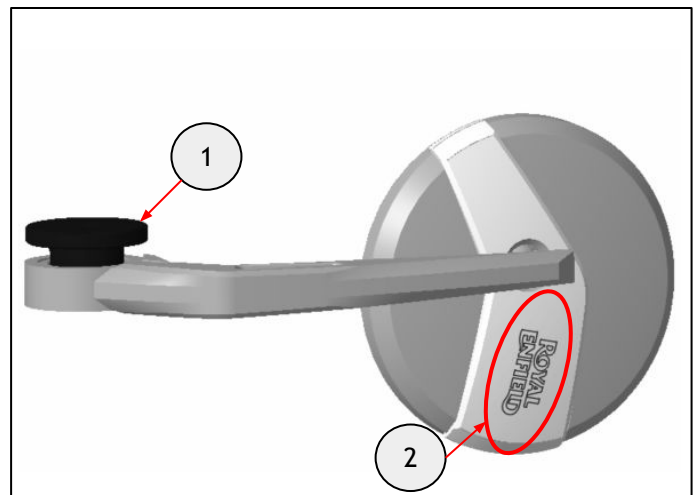

4 Tighten the fixing (1) to 8 Nm.

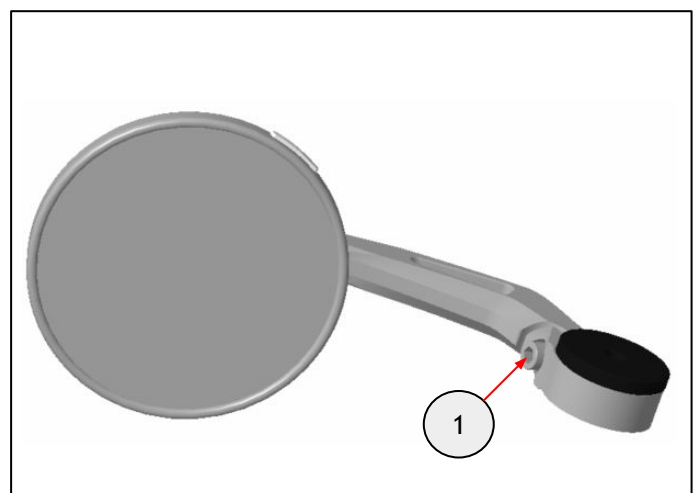
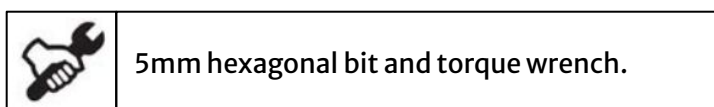

5 Remove the bar end weight (1) by removing the fixing (2). Retain for reuse if not fitting a bar end finisher. Alternatively, retain for reuse if the motorcycle is to be returned to its original condition.



5mm hexagonal bit and ratchet.

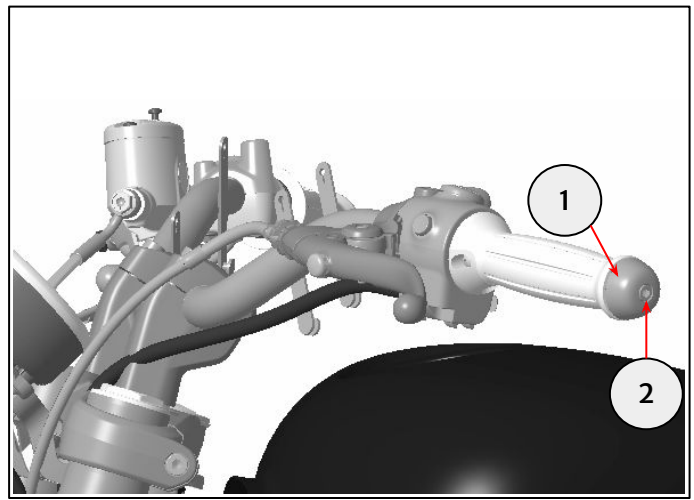

Fitment of mirror with bar end finisher:

6 Fit the mirror assembly (1) and the finisher (2) to the bar end using the countersunk fixing (3) from the mounting kit.

Tighten the fixing to 10 Nm.

Remove the protective film from the mirror, adjust and set the mirror angle to a comfortable viewing position.



5mm hexagonal bit and torque wrench.

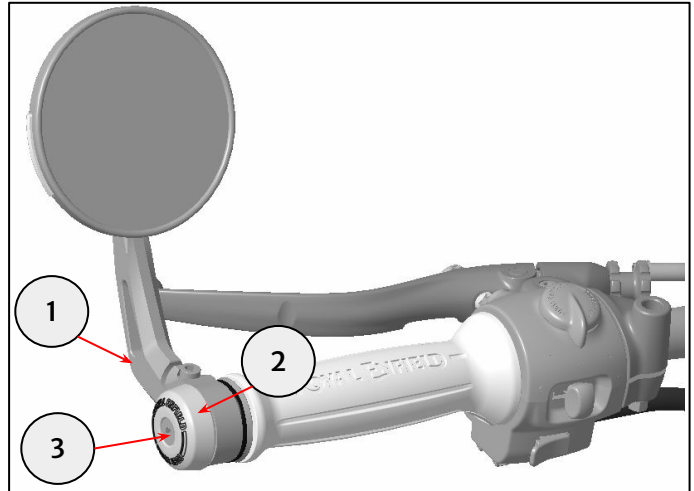

7 Repeat steps 2 to 6 on the right side.



WARNING: Do not fit both the bar end mirrors and standard mirrors simultaneously.

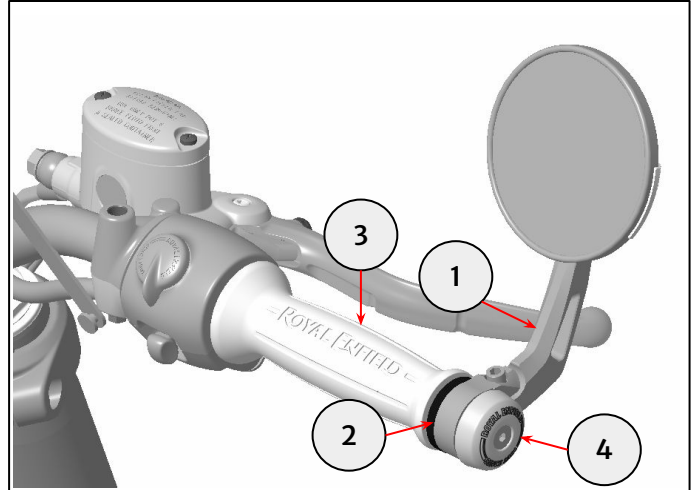

WARNING: Ensure there is clearance between the bar end mirror (1), the bar end mirror mount (2) and twist grip (3). The operation of the twist grip should be smooth, without tightness and return to the throttle closed position when released. A tight, sticking or restricted twist grip can lead to loss of motorcycle control and an accident.



WARNING: Turn the handlebar to the left hand and right hand full lock position and check that the bar end finisher (4) does not contact any part of the motorcycle, or restrict the steering in any way. A motorcycle which has the steering restricted may become unstable and result in an accident.



WARNING: After fitting any genuine Royal Enfield accessory always ride the motorcycle with caution and allow time to become familiar with any change in the motorcycle handling characteristics. Failure to become familiar with any change in the motorcycle handling characteristics may cause the motorcycle to become unstable and result in an accident.

Fitment of mirrors with standard bar end weights:

8 Repeat steps 6 and 7 using the bar end weights removed in step 5 and the cap head fixing from the mounting kit.

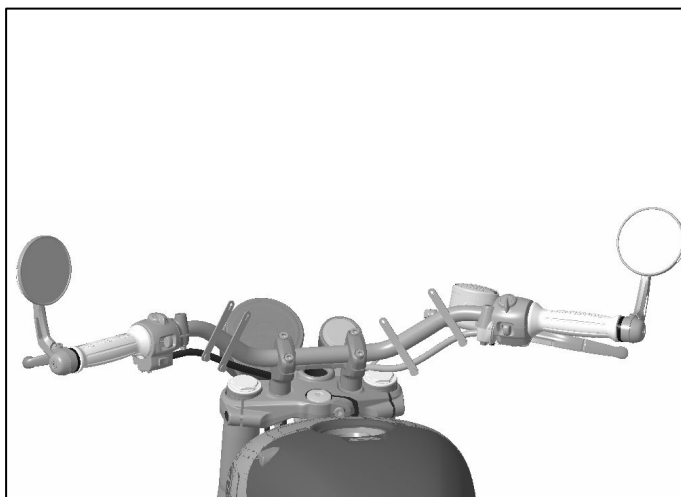

Fitment of the bar end finishers with standard mirrors:

9 Fit the bar end finisher (1) to the bar end using the fixing (2) from the kit.

Tighten the fixing to **10Nm**.

Repeat this step on the right side.



5mm hexagonal bit and torque wrench.

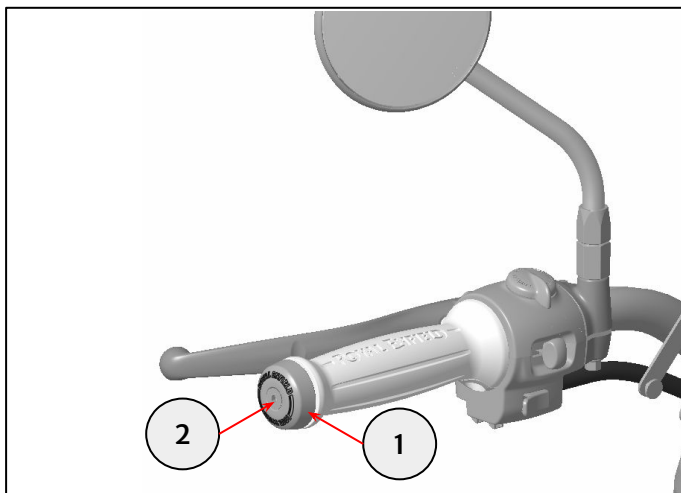

WARNING: Turn the handlebar to the left hand and right hand full lock position and check that the bar end finisher (1) do not contact any part of the motorcycle, or restrict the steering in any way. A motorcycle which has the steering restricted may become unstable and result in an accident.



WARNING: After fitting any genuine Royal Enfield accessory always ride the motorcycle with caution and allow time to become familiar with any change in the motorcycle handling characteristics. Failure to become familiar with any change in the motorcycle handling characteristics may cause the motorcycle to become unstable and result in an accident.