

**Part Number:**

1990413 – Short Tinted Flyscreen  
1990414 – Tall Tinted Flyscreen  
1990468 – Black Painted Instrument Cowl

**Models:**

Continental GT 650 (2018 onwards)  
Interceptor INT 650 (2018 onwards)  
INT 650 (US Only) (2018 onwards)  
Continental GT 650 With VIN starting ME3P7E6FHN1  
Interceptor INT 650 With VIN starting ME3P7F6FHN1



**WARNING:** Royal Enfield genuine accessories are designed to fit only the specific Royal Enfield motorcycle(s) that are specified above. They should not be fitted to any other type of motorcycle. Pay particular attention to the warnings and cautions contained in this instruction, failure to do so may result in an incorrect installation of the accessory which could result in an unsafe riding condition and possible accident. If in any doubt always seek help from your authorised Royal Enfield dealer.



**WARNING:** Before starting any accessory kit installation, ensure the motorcycle is supported in a stable condition. Failure to support the motorcycle correctly could lead to motorcycle damage or personal injury.



**WARNING:** All fixings must be tightened to the torque values specified in this instruction. Failure to tighten fixings to the correct torque could result in an unsafe riding condition and possible accident.



**CAUTION:** Care should be taken when fitting any accessory kit. Incorrect handling of kit components or the use of incorrect tools could lead to component or motorcycle damage.

**NOTE:** The content of this instruction is subject to change at any time without notice or liability. Royal Enfield reserves the right to revise the information presented at any time.

**Parts Supplied: 1990413**

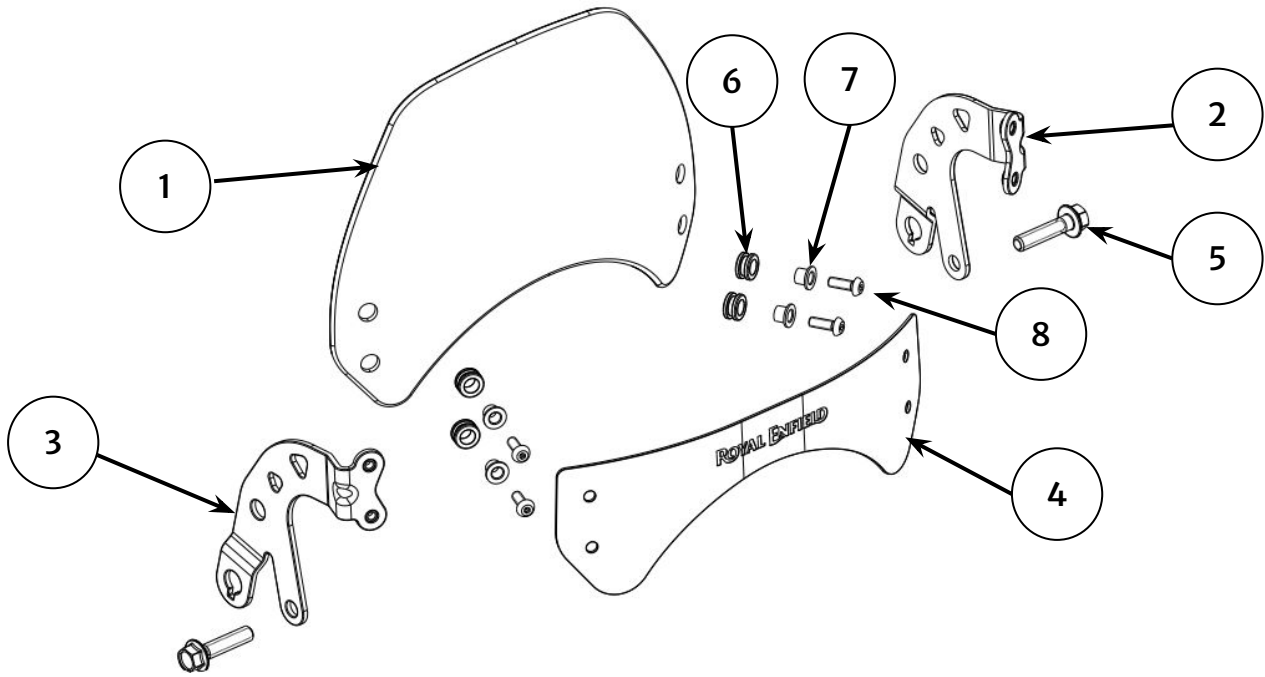

Item	Description	Qty
1	Short flyscreen	1
2	Mounting bracket, left hand	1
3	Mounting bracket, right hand	1
4	Embellisher	1
5	Fixing M8 x 45mm	2
6	Grommet	4
7	Top Hat	4
8	Fixing M5 x 16mm	4

**Parts Supplied: 1990414**

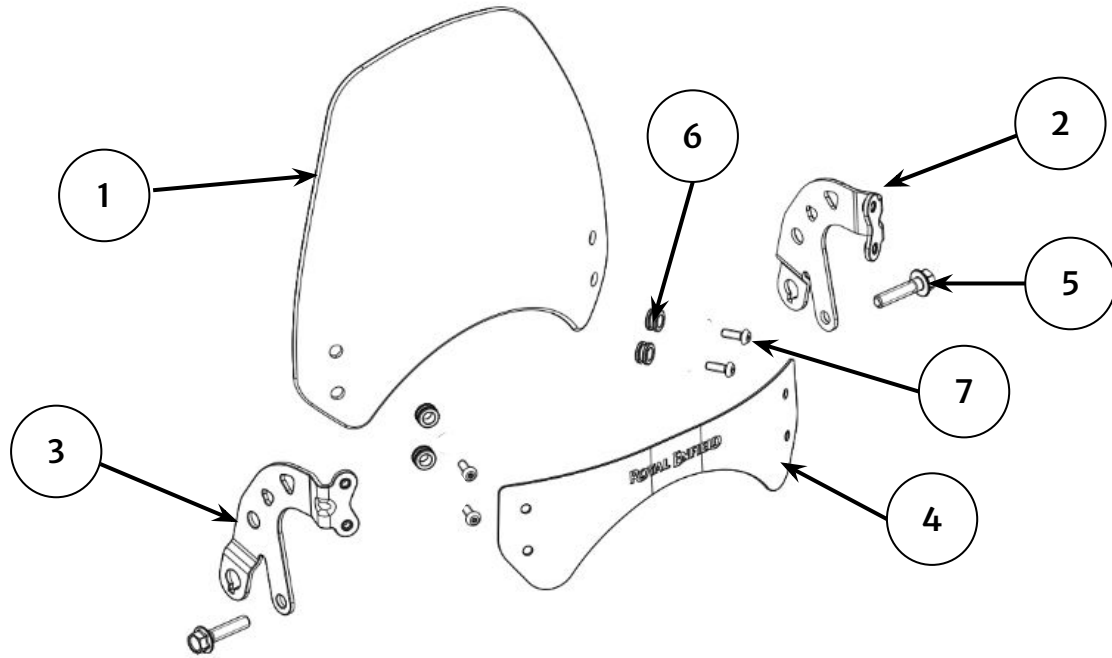

Item	Description	Qty
1	Tall flyscreen	1
2	Mounting bracket, left hand	1
3	Mounting bracket, right hand	1
4	Embellisher	1
5	Fixing M8 x 45mm	2
6	Grommet	4
7	Fixing M5 x 16mm	4

**Parts Supplied: 1990468**

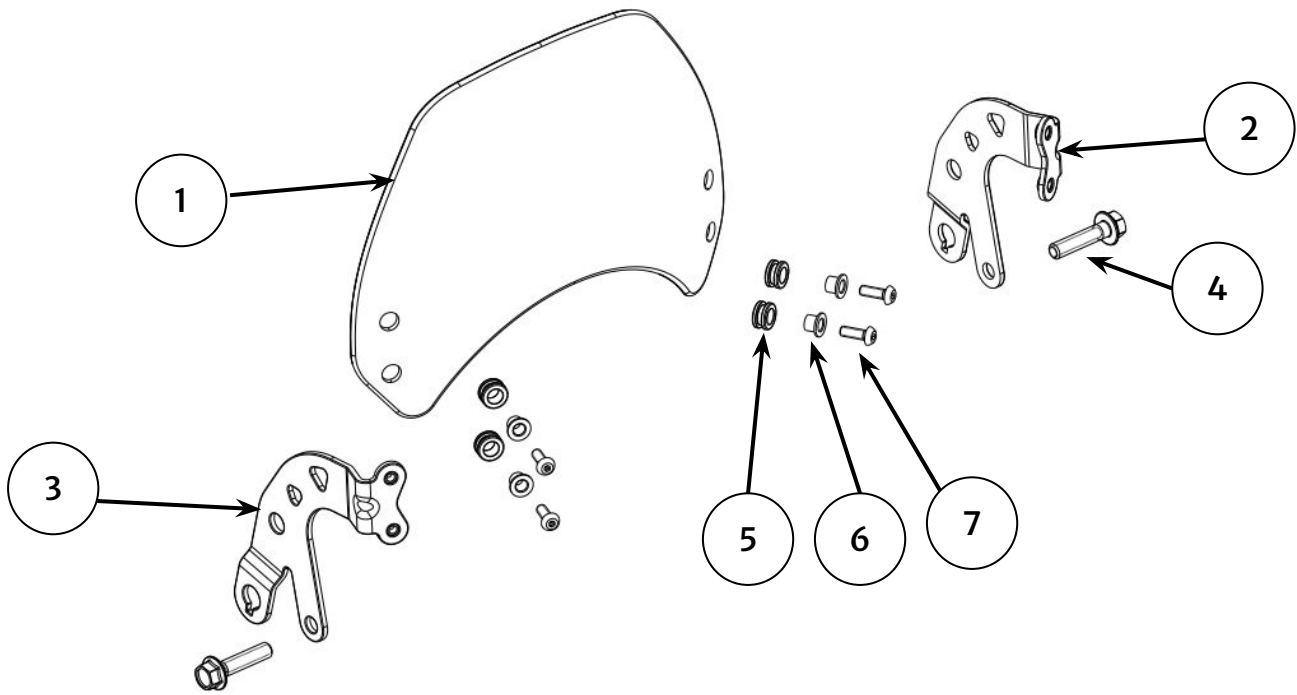

Item	Description	Qty
1	Painted flyscreen	1
2	Mounting bracket, left hand	1
3	Mounting bracket, right hand	1
4	Fixing M8 x 45mm	2
5	Grommet	4
6	Top Hat	4
7	Fixing M5 x 16mm	4

**NOTE:** Before starting fitment ensure ignition is OFF and disconnect the negative terminal from the battery, as described in the Owner's Manual.

**1** Carefully remove the headlamp from headlamp assembly by removing the fixings (1) on both left and right side of headlamp assembly. Retain the fixings for reuse. Disconnect headlamp connector from vehicle connector.



Phillips Screwdriver / PH1 phillips bit and ratchet.

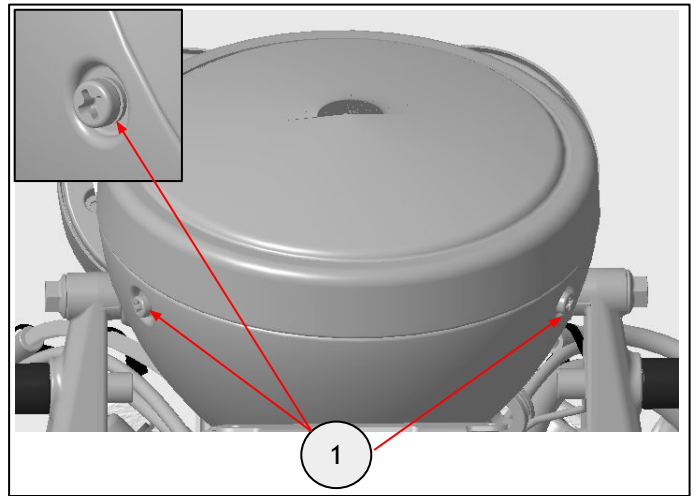

**2** Remove the headlight bowl fixing (1) on both sides and retain the fixings for reuse. Carefully remove the headlight bowl from the vehicle.



12mm socket and ratchet.

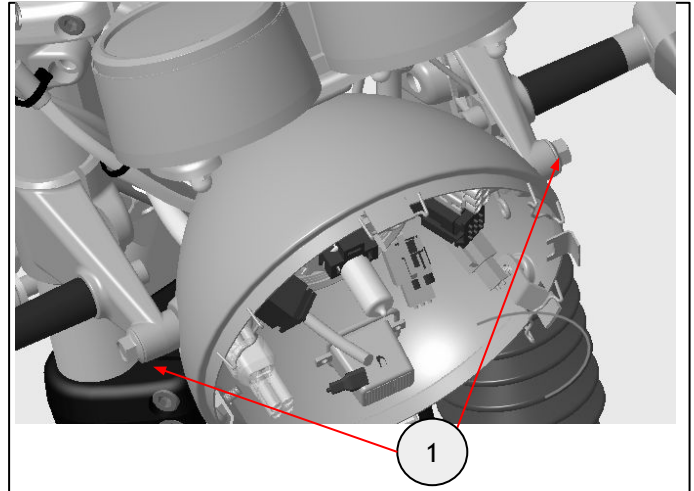

**3** Remove left hand Indicator connectors inside the headlamp assembly and remove the indicator fixings (1 & 2), Retain the indicator (3) and fixings (1 & 2) for reuse.



19mm socket and ratchet.

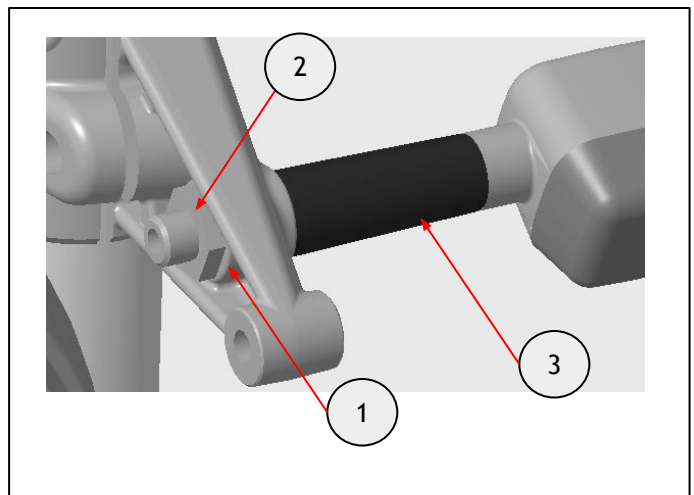

**4** Locate the left hand mounting bracket (1) from the kit on to the headlight holder mounting (2) in the orientation shown.

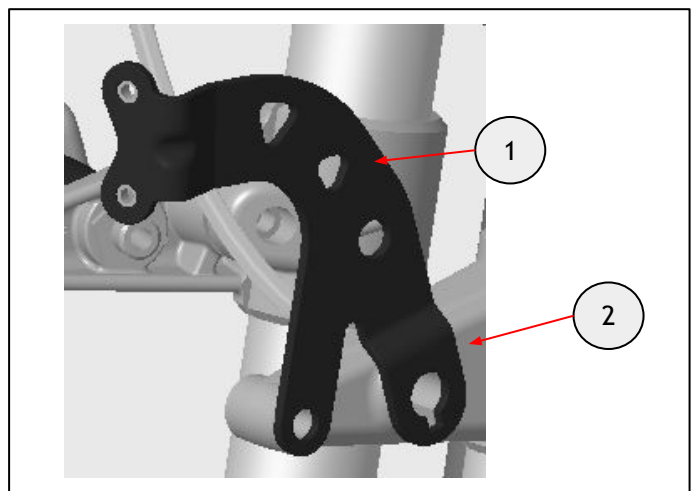

**5** Refit the left hand indicator (1), feeding the indicator harness through the mounting bracket (2) and headlight holder (3) as shown. Refit the original fixings (4 & 5) to the indicator. Ensure the fixings are tightened sufficiently to retain the indicator securely. Tighten the fixing (5) to **8 Nm**. Hold the indicator in hand to avoid the indicator rotating while tightening the fixing (5).

	<p>19mm socket and torque wrench.</p>
--	---------------------------------------

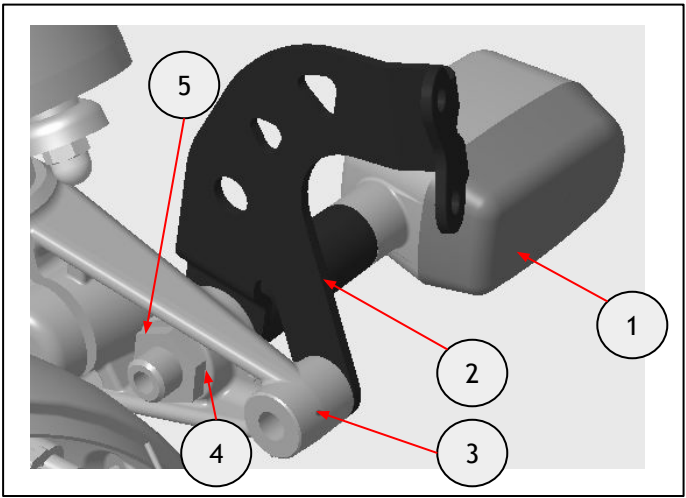

**6** Repeat steps 3 to 5 for the right hand side flyscreen bracket fitment (1).

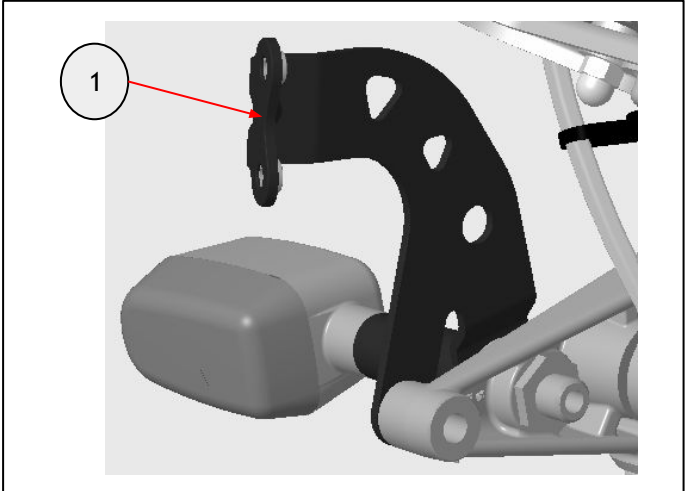

**7** Assemble the headlamp bowl (1) to its original position and refit the original fixing (2) on both left and right hand sides. Tighten the fixing (2) to **25 Nm**.

**NOTE:** Ensure the indicator harness is routed correctly in to the headlight bowl. A wiring harness which becomes trapped or pinched during installation may lead to wiring harness damage and electrical malfunctions.

**NOTE:** For flyscreen and painted instrument cowl fitment reuse the fixings (1) for 2018 onwards released models. Use CAP fixings (M8x45mm) from the kit for the VIN starting ME3P7E6FHN1 and ME3P7F6FHN1.

	<p>12mm socket and torque wrench.</p>
--	---------------------------------------

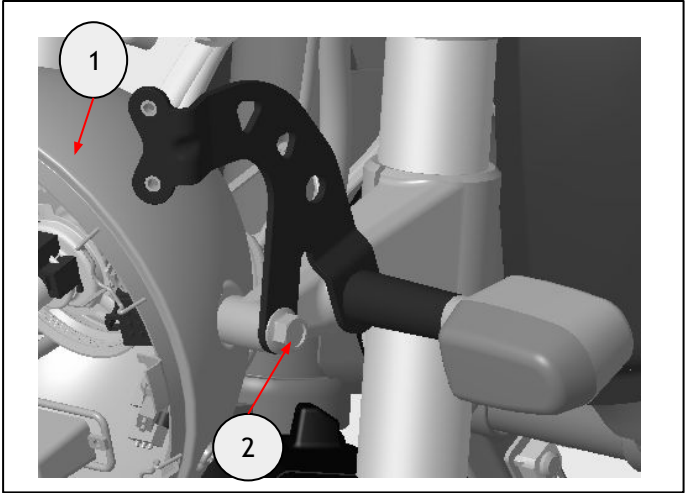

**8** Refit the headlight assembly (1) to the headlight bowl (2) and tighten the fixings (3) at the sides of the headlight bowl to **5 Nm**.

	<p>PH1 Phillips bit and torque wrench</p>
--	---

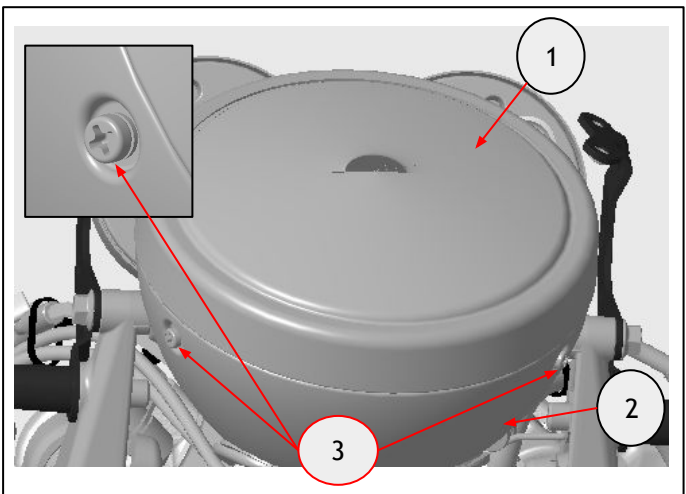

**9** Fit the four grommets (1), top hat (2) from the kit into the flyscreen as shown.

**NOTE:** The top hat (2) is not fitted to the tall flyscreen. The top hat (2) is to be fitted to the short and painted flyscreens only.

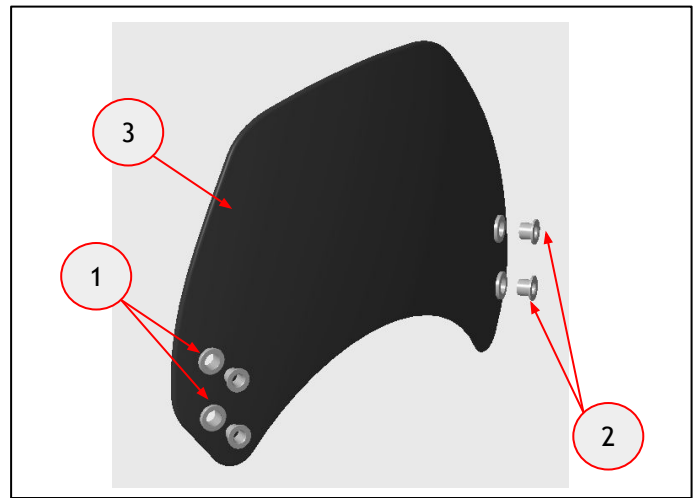

**10** Position the flyscreen (1) over the bracket (2) and position the embellisher (3) over the flyscreen (1) and align the fixing positions on both sides. Fit the fixings (4) from the kit. Tighten the fixings **2 Nm** to tall flyscreen. Tighten the fixings **4 Nm** to short and painted flyscreen.

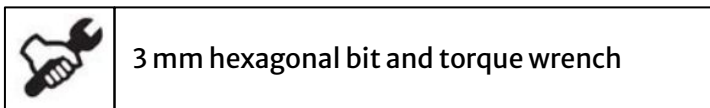

**NOTE:** The embellisher is not fitted to Painted flyscreens. Ensure both foam pads are present on the rear of the embellisher before fitting the embellisher to the flyscreen.

**NOTE:** Reconnect the negative terminal to battery as described in the Owner's Manual.

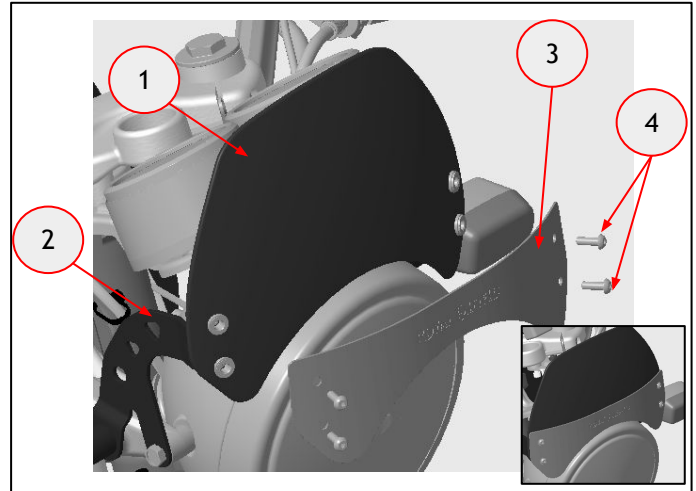

**WARNING:** After fitting any genuine Royal Enfield accessory always ride the motorcycle with caution and allow time to become familiar with any change in the motorcycle handling characteristics. Failure to become familiar with any change in the motorcycle handling characteristics may cause the motorcycle to become unstable and result in an accident.