

Part Number:

1990200,1990227,1990230,1990232,1990201

Models:

Himalayan

WARNING: Royal Enfield genuine accessories are designed to fit only the specific Royal Enfield motorcycle(s) that are specified above. They should not be fitted to any other type of motorcycle. Pay particular attention to the warnings and cautions contained in this instruction, failure to do so may result in an incorrect installation of the accessory which could result in an unsafe riding condition and possible accident. If in any doubt always seek the help from your authorised Royal Enfield dealer.

WARNING: Before starting any accessory kit installation ensure the motorcycle is supported in a stable condition. Failure to support the motorcycle correctly could lead to motorcycle damage or personal injury.

WARNING: All fixings must be tightened to the torque values specified in this instruction. Failure to tighten fixings to the correct torque could result in an unsafe riding condition and possible accident.

CAUTION: Care should be taken when fitting any accessory kit. Incorrect handling kit components or the use of incorrect tools could lead to component or motorcycle damage.

NOTE: The content of this instruction is subject to change at any time without notice or liability. Royal Enfield reserves the right to revise the information presented at any time.

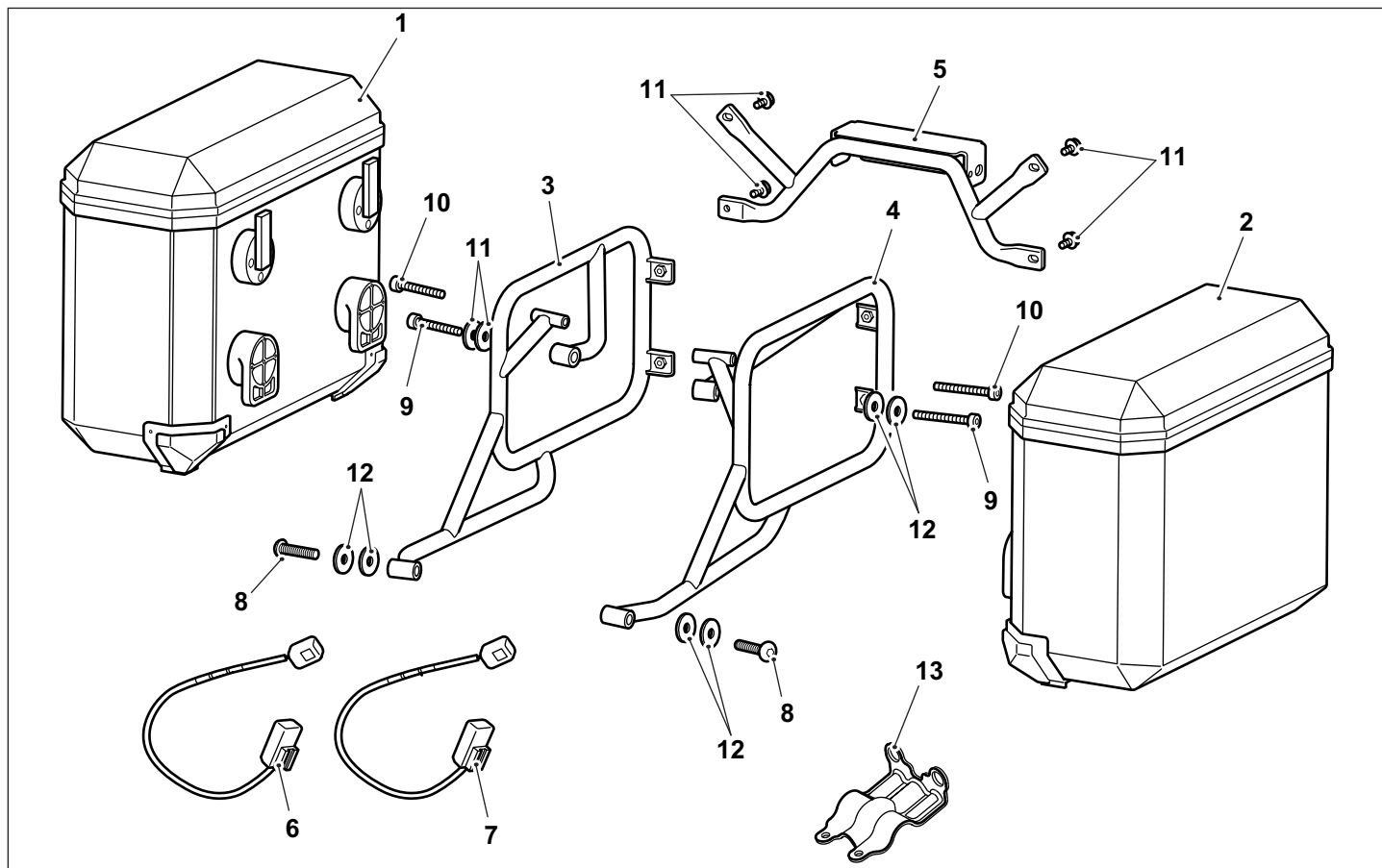

Item	Description	Qty
1	Pannier, right hand	1
2	Pannier, left hand	1
3	Pannier rail, right hand	1
4	Pannier rail, left hand	1
5	Connector bar	1
6	Extension harness (red connectors)	1

Item	Description	Qty
7	Extension harness (green connectors)	1
8	Fixing, M8 x 45mm, Button head	2
9	Fixing, M8 x 60mm, Cap head	2
10	Fixing, M8 x 70mm, Cap head	2
11	Fixing, M6x15mm, Flange hex head	4
12	Washer, M8	8
13	Tail light bracket	1

Installing the Pannier Rails

- 1** Ensure the motorcycle is placed on the centre stand prior to commencing any work.
- 2** Remove the rider and pillion seats, as described in the Owner's Handbook.
- 3** Disconnect the battery, negative lead first.
- 4** Remove infill panel and numberplate hanger rear fixings (2) from the underside of the rear mudguard. Retain the fixings for reuse.

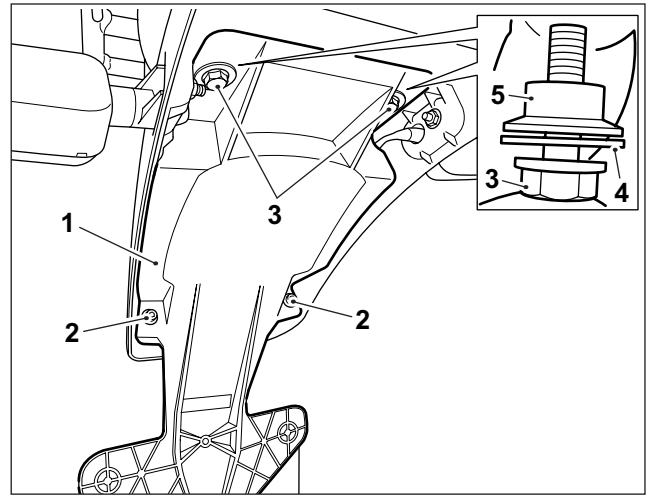

4mm Allen socket with ratchet

While supporting the infill panel and numberplate hanger (1) remove the two front fixings (3). Retain the fixings (3), washers (4) and rubber sleeves (5) for reuse.



10mm Bi-hexagonal socket with ratchet

- 5** Carefully lower the infill panel and number plate hanger from the underside of the rear mudguard and disconnect the numberplate light harness connector (1) from the main wiring harness connector (2).

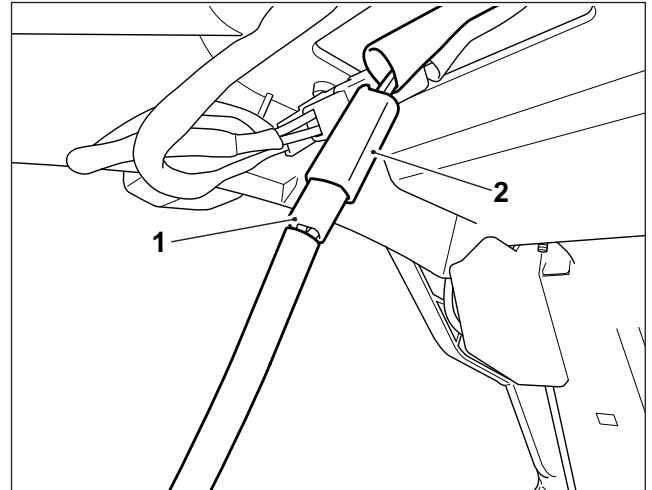

Retain the infill panel and number plate hanger for reuse.

- 6** Disconnect the right hand indicator harness (GREEN) (1) and left hand indicator harness (RED) (2) from the main wiring harness (3).

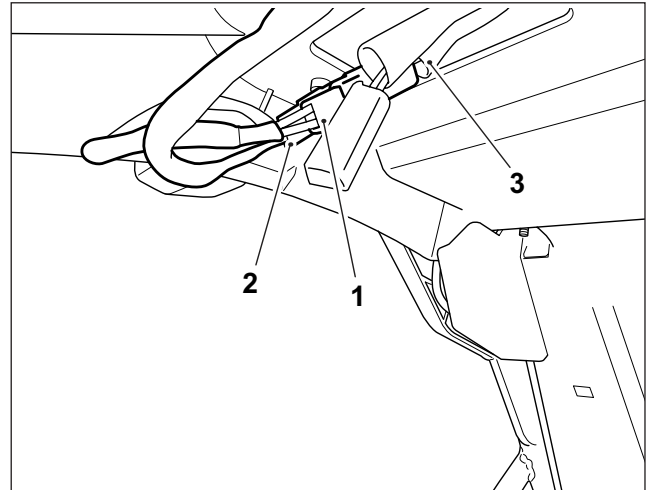

- 7** Remove the left hand and right hand rear indicators. Retain the indicators (1), fixings (2) and nuts (3) for reuse.



4mm Allen socket with ratchet

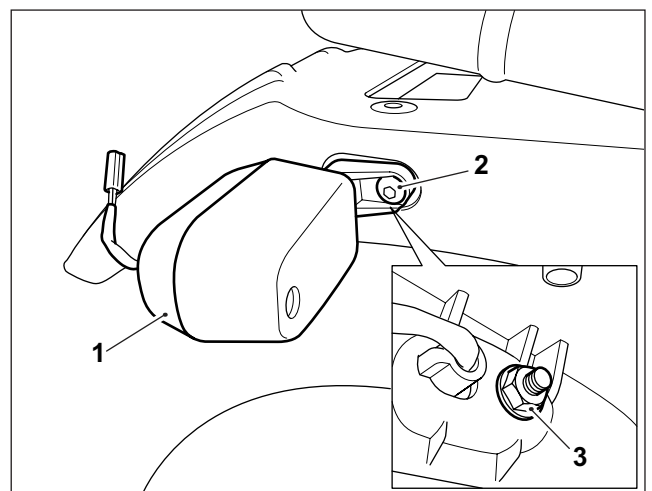

8 Remove the front luggage rack fixings (1) from both right and left side. Retain the fixings for future reuse if the accessory pannier kit is removed.

Remove the left and right hand rear saddle bag mounting fixings (2). Retain the fixings for future reuse if the accessory pannier kit is removed.

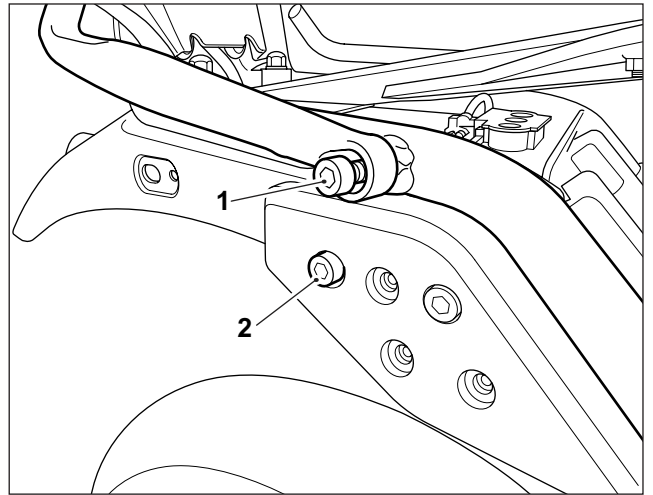
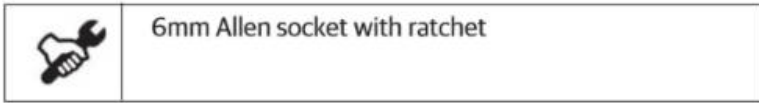

9 Loosen the grab rail (1) rear fixings (2). Do not remove the fixings.

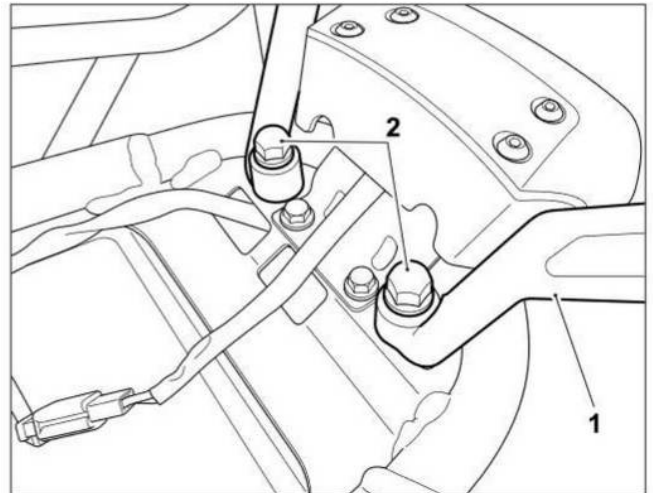
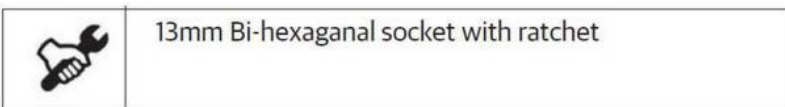

10 Ensure all pannier rail fitting bosses are free from foreign material and fasteners run freely into threads. Position the right hand pannier rail (1) on the motorcycle ensuring the top rear mounting (2) is correctly located in the luggage rack mounting recess (3), as shown.

Align the pannier rail front mounting (4) with the fixing position on the motorcycle frame (5) and loosely fit an M8 x 45mm fixing (6) and two M8 washers (7) from the kit.

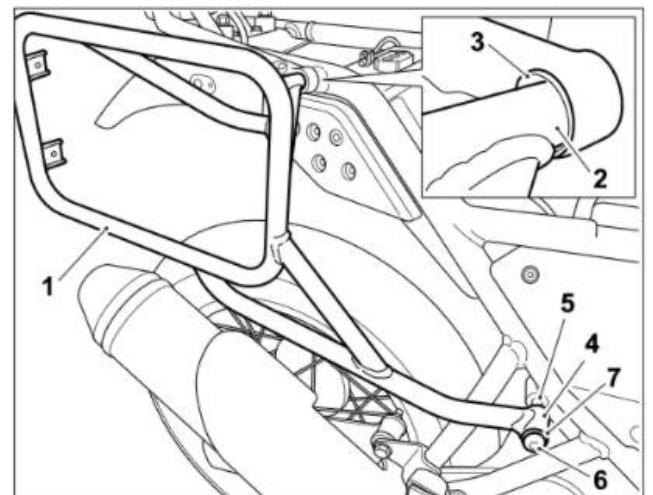
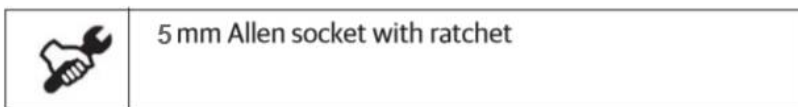

11 Loosely fit an M8 x 70mm fixing (1) from the kit to the pannier rail luggage rack mounting position (2).

Loosely fit an M8 x 60mm fixing (3) and two M8 washers (4) from the kit to the pannier rail and saddlebag mounting position (5), as shown.

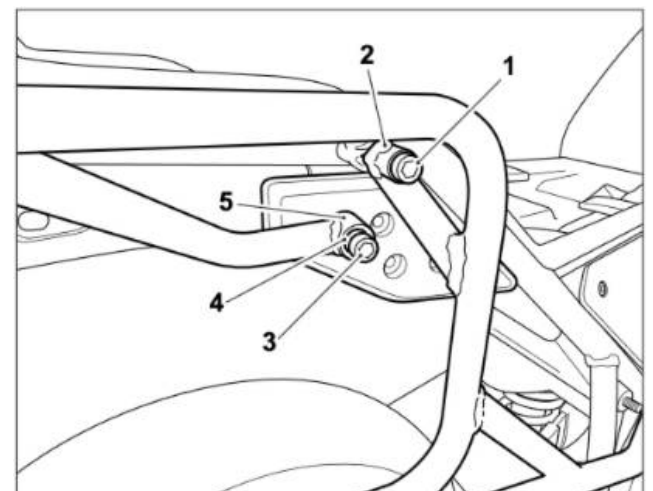
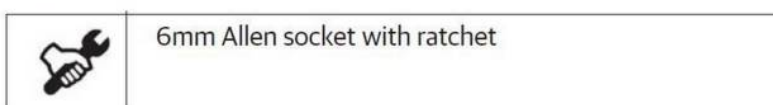

Do not fully tighten any pannier rail fixings at this stage.

Repeat steps 10 to 11 for the left hand pannier rail

12 Disconnect the rear light harness connector from the main wiring harness (3). Remove the two rear light mounting bracket (1) M5 x 10mm fixings (2). Retain the fixings for reuse.



8mm Bi-hexagonal socket with ratchet

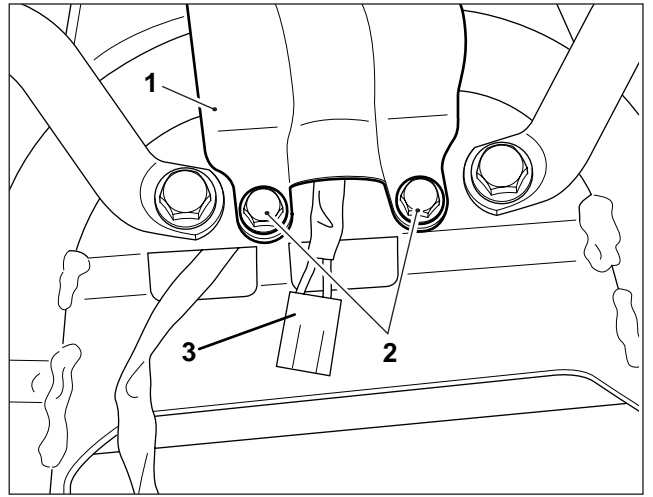

13 Remove the two lower M5 x 14mm rear light fixings (1). Retain the fixings for reuse.



3mm Allen socket with ratchet

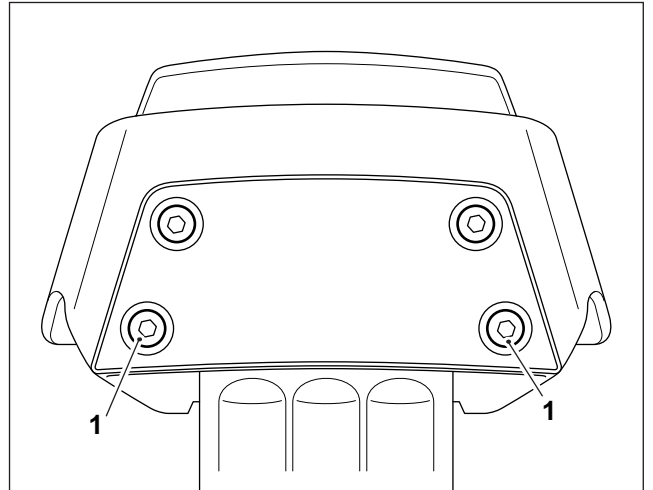

14 Carefully release the retaining clips (1) securing the front cover (2) of the rear light housing. Retain the front cover for reuse.

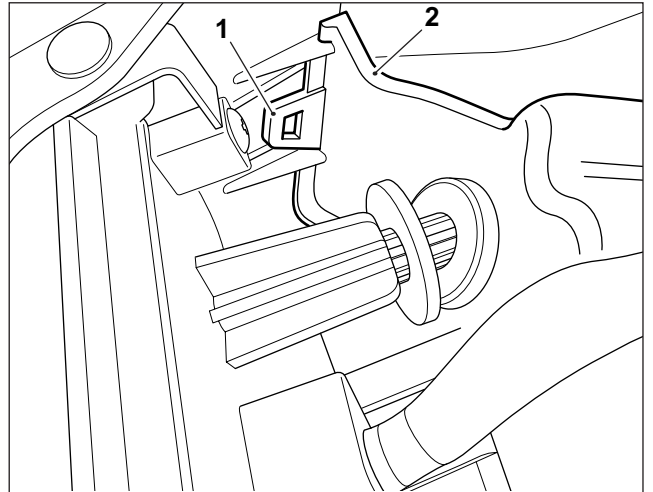

15 Remove the two self tapping fixings (1) and washers (2) from the rear light housing. Retain the fixings and washers for reuse. Remove the rear light mounting bracket (3) from the rear light housing.



Pozi-drive (PZ2) with ratchet

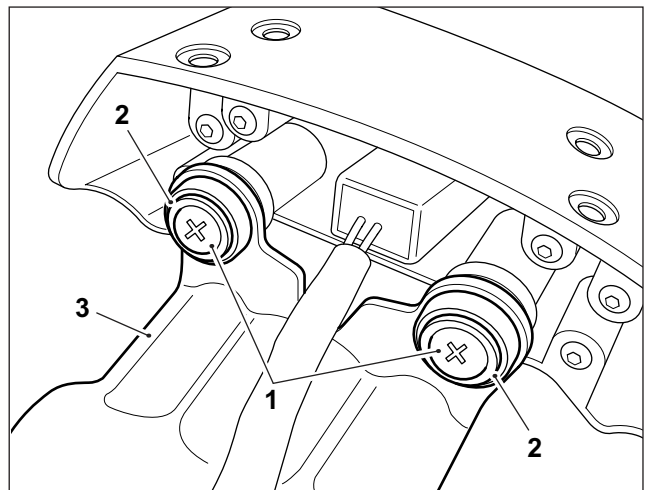

16 Remove the grommets (1) from the original rear light mounting bracket and fit them in to the rear light mounting bracket (2) from the kit as shown.
Retain the original rear light mounting bracket for reuse if the accessory panniers are removed.

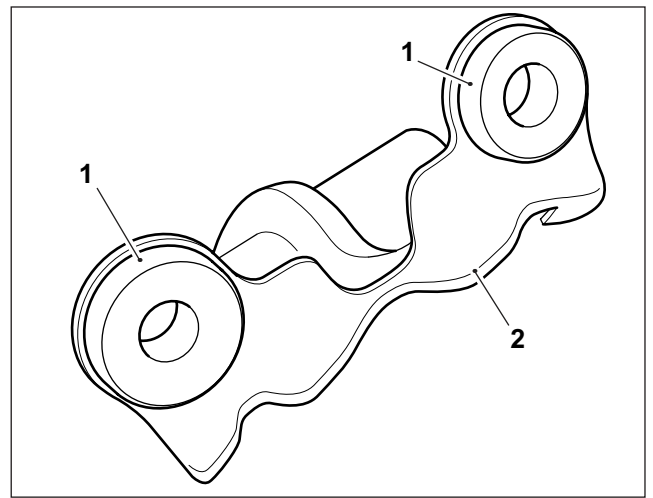

17 Fit the original larger washers (1) on to the rear light housing mounting flanges (2). Fit the rear light mounting bracket (3) on to the rear light housing in the orientation shown. Fit the original self tapping fixings (4) and smaller washers (5). Tighten the fixings to **2 Nm**.

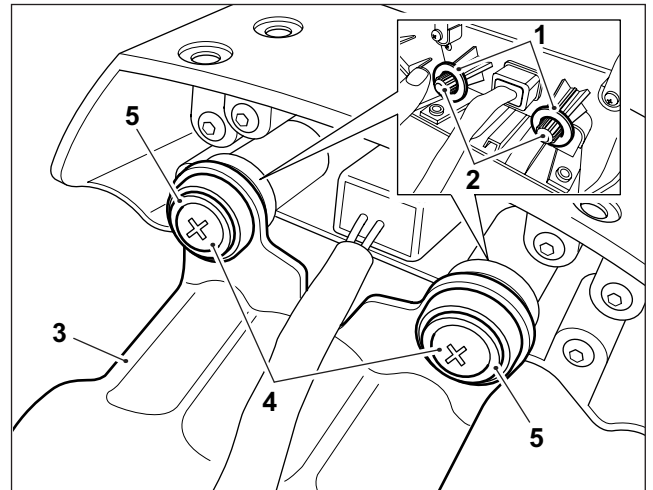

 Pozi-drive (PZ2) with torque wrench

18 Refit the rear light housing front cover (1) and clip in to position. Refit the two original M5 x 14mm fixings. Tighten the fixings to **2 Nm**.

 3mm Allen socket with torque wrench

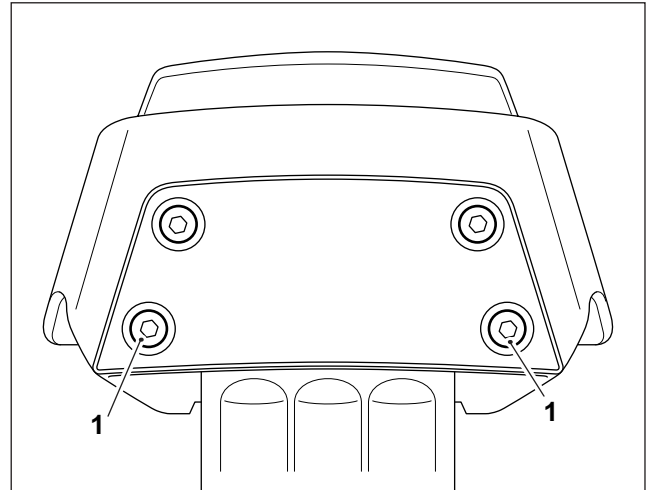

19 Refit the rear light assembly ensuring the rear light harness (1) is correctly located under the rear light mounting bracket (2), as shown. Fit the original M5x 10mm fixings (3) and tighten to **10 Nm**. Reconnect the rear light harness connector (4) to the main wiring harness (5).

 8mm Bi-hexagonal socket with torque wrench

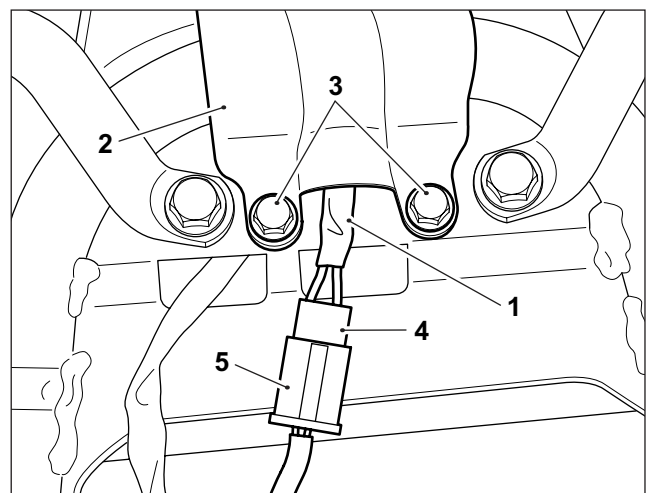

20 Align the rear connector bar (1) with the fixing positions on the right hand (2) and left hand (3) pannier rails.

Fit the M6 x 15mm fixings (4) from the kit to secure the connector bar to the pannier rails.

Do not fully tighten the fixings at this stage.



10mm Bi-hexagonal socket with ratchet

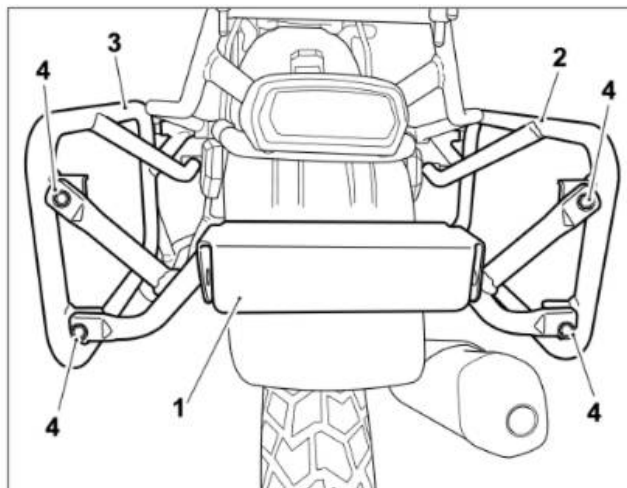

21 Looking from the rear of the motorcycle ensure the left hand (1) and right hand (2) pannier rails are centralised on the motorcycle, as shown.

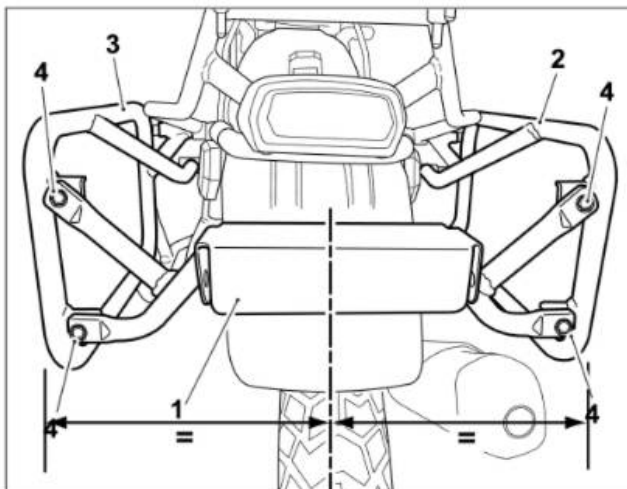

22 Tighten the pannier rail front fixings (1) to **22 Nm**.



6mm Allen socket with torque wrench



5mm Allen socket with torque wrench

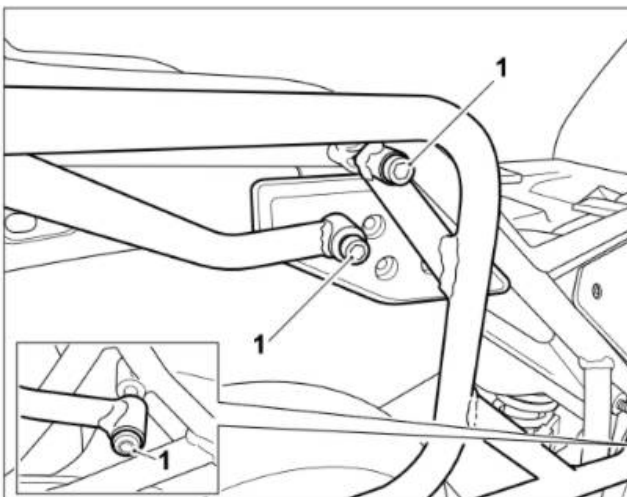

23 Tighten the rear connector bar fixings (1) to **10 Nm**.



10mm Bi-hexagonal socket with torque wrench

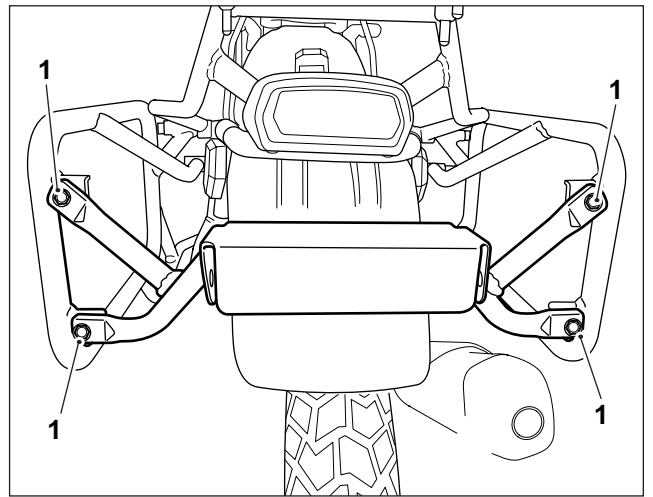

24 Tighten the grab rail (1) rear fixings (2) to **25 Nm**.



13mm Bi-hexagonal socket with torque wrench

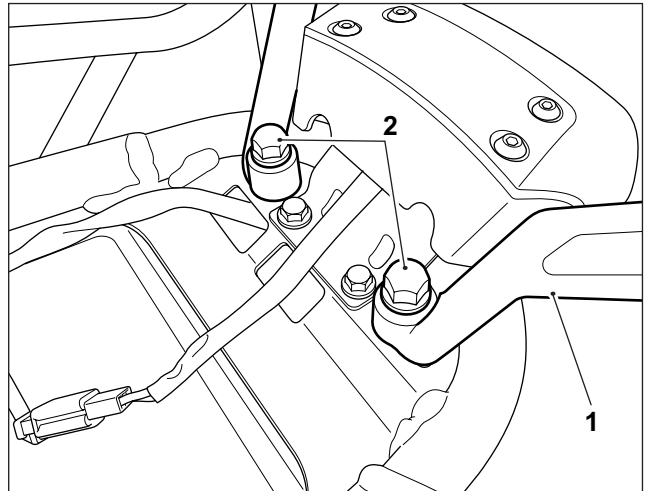

25 Route the right hand indicator harness (1) through the indicator mounting hole in the right hand side of the connector bar (2), as shown.

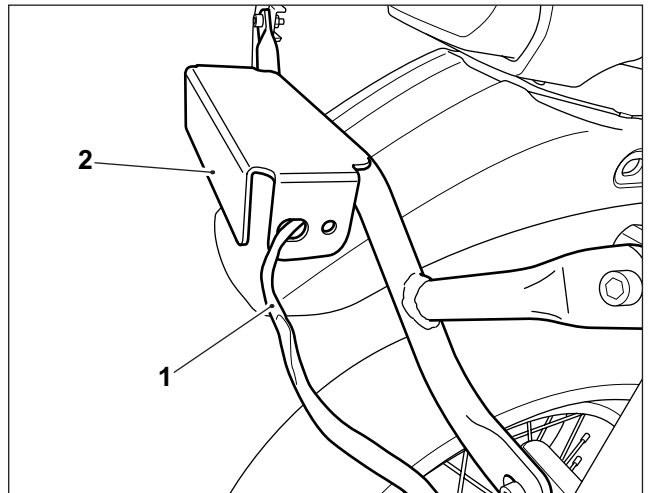

26 Fit the right hand indicator (1) to the right hand side of the connector bar (2) and secure with the original fixing (3) and nut (4). Tighten the nut to **5 Nm**.



4mm Allen socket with torque wrench

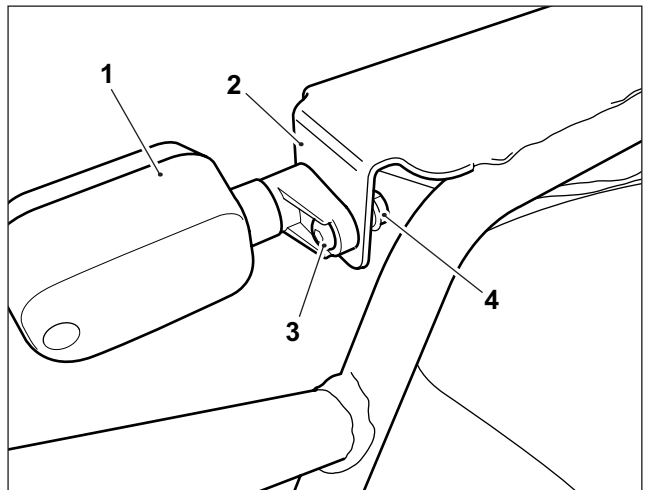

Repeat steps 25 and 26 for the left hand indicator.

27 Connect the indicator extension harnesses (1) from the kit to the main wiring harness (2).

NOTE: The extension harness with the GREEN connectors must be connected to the main harness GREEN connector and the extension harness with the RED connectors must be connected to the main harness RED connector.

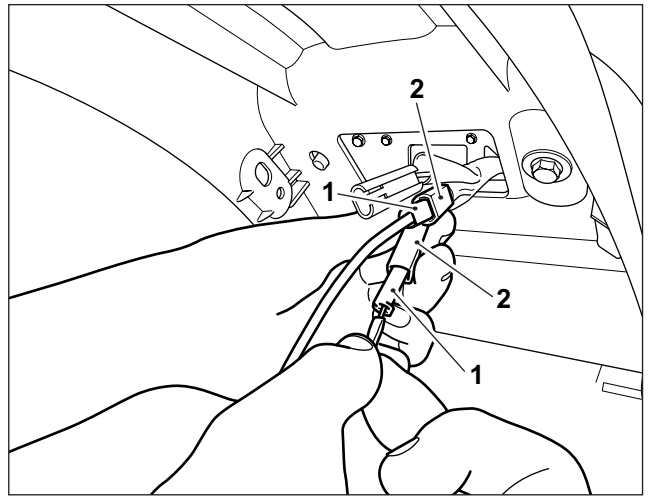

28 Connect the indicator harness extensions (1) to the left hand indicator harness (2) and right hand indicator harness (3).

NOTE: The extension harness with the GREEN connector must be connected to the right hand indicator harness and the extension harness with the RED connector must be connected to the left hand indicator harness.

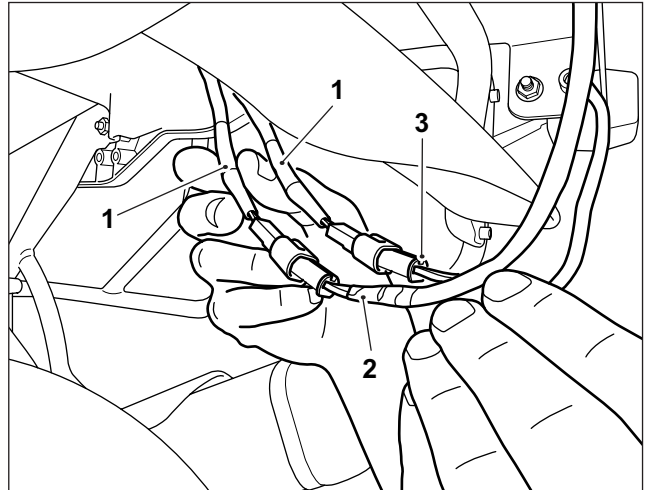

29 Reconnect the numberplate light harness (1) to the main wiring harness (2).

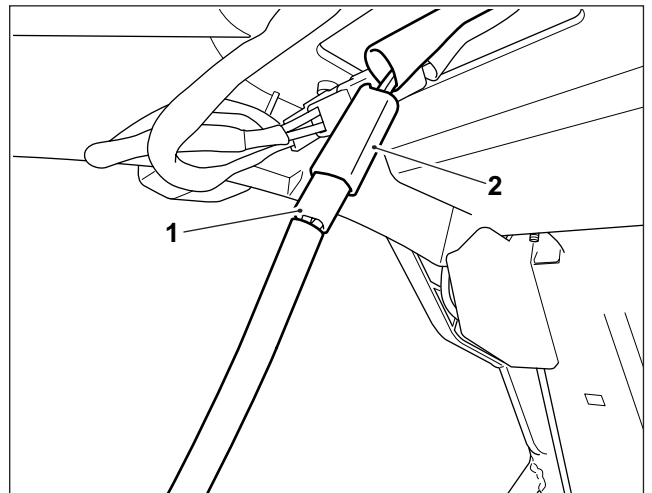

30 Refit the infill panel and numberplate hanger (1) to the underside of the rear mudguard (2) ensuring the indicator harnesses (3) are routed in the infill panel recesses (4), as shown.

CAUTION: Ensure the re-routed indicator wiring harnesses are not trapped between the infill panel and rear mudguard. A wiring harness which becomes trapped during installation can result in equipment malfunction.

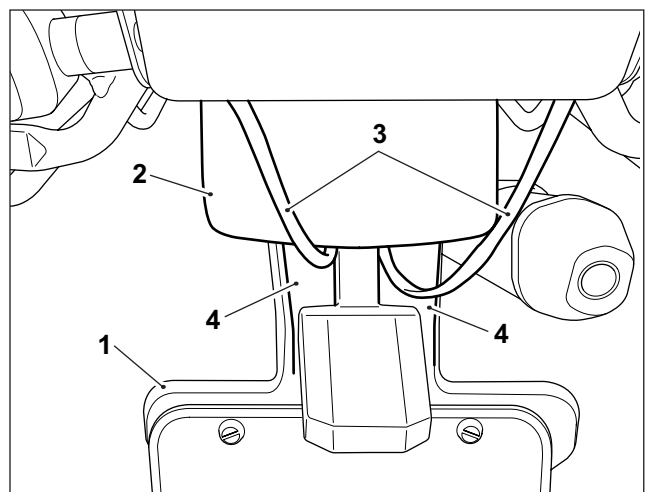

31 Secure the infill panel and numberplate hanger (1) with the original front fixings (2) and rear fixings (5). Ensure the front fixings (2), washers (3) and rubber sleeves (4) are positioned as shown. Tighten the rear fixings (5) to **5 Nm**. Tighten the front fixings (2) to **10 Nm**.

	<p>10mm Bi-hexagonal socket with torque wrench 4mm Allen socket with torque wrench</p>
---	--

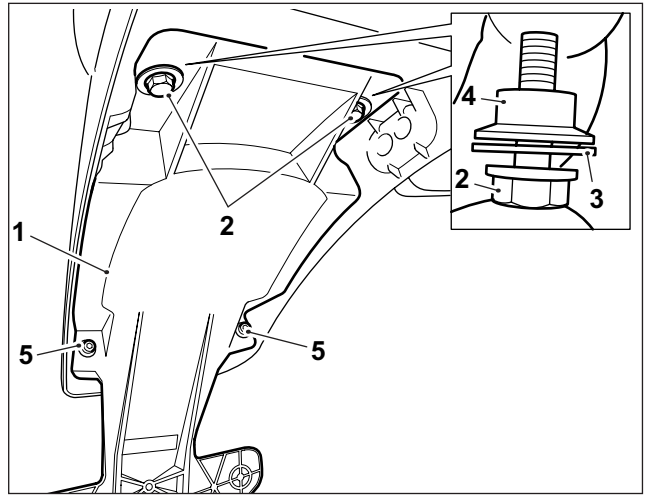

32 Reconnect the battery, positive lead first and check that the indicators and rear numberplate light function correctly.

Refit the rider and pillion seats, as described in the Owner's Handbook.

Installing the Panniers

1 Collect the left hand pannier from the kit. From inside the pannier (1), loosen the upper mount fixings (2).

	<p>By hand only</p>
---	---------------------

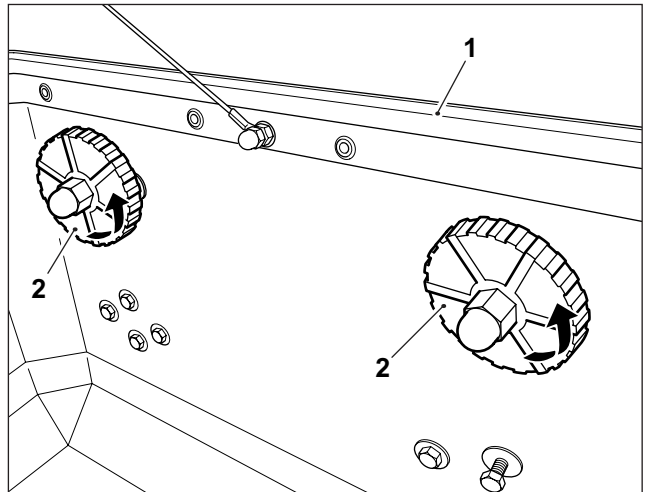

2 Adjust the position of the upper mount retaining bars (1) until they are facing towards the bottom of the pannier (2) as shown.

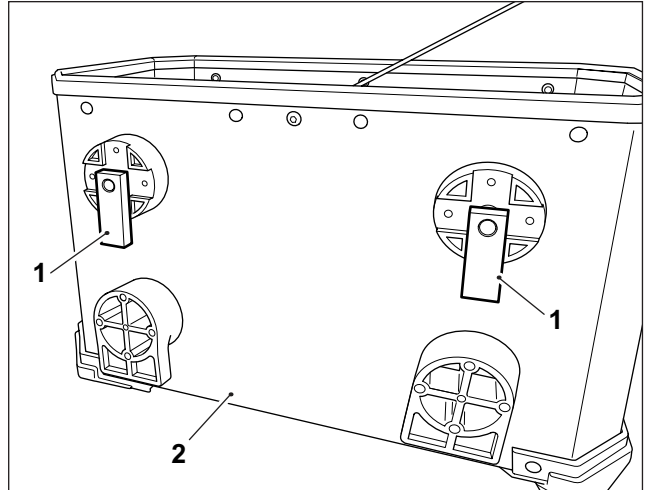

3 Position the pannier on the left hand pannier rail (1) ensuring the lower pannier mounts (2) are located inside the pannier rail (1). Push the lower pannier mounts (2) onto the pannier rail (1) as shown.

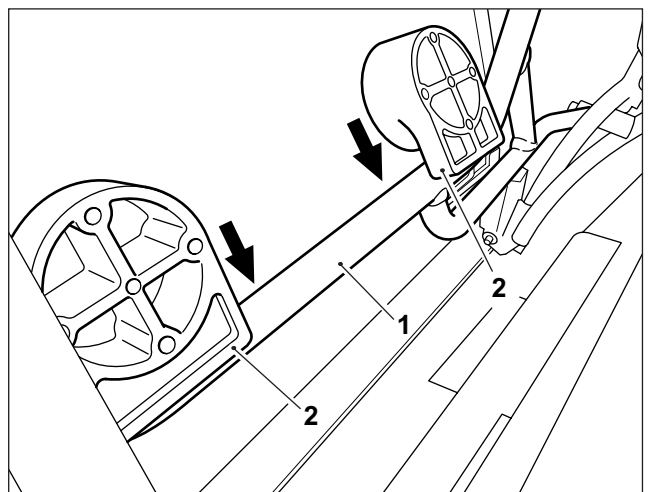

4 Position the pannier upper mounts (1) inside the pannier rail (2). Adjust the position of the pannier upper mount retaining bars (3) until they are across the pannier rail (2).

CAUTION: Ensure there is sufficient clearance between the pannier rail and upper mount retaining bars to prevent damage to the pannier rail when adjusting the position of the upper mount retaining bars.

From inside the pannier, tighten the upper mount fixings (4) to secure the pannier to the pannier rail.

Repeat steps 1 to 4 for the right hand pannier.

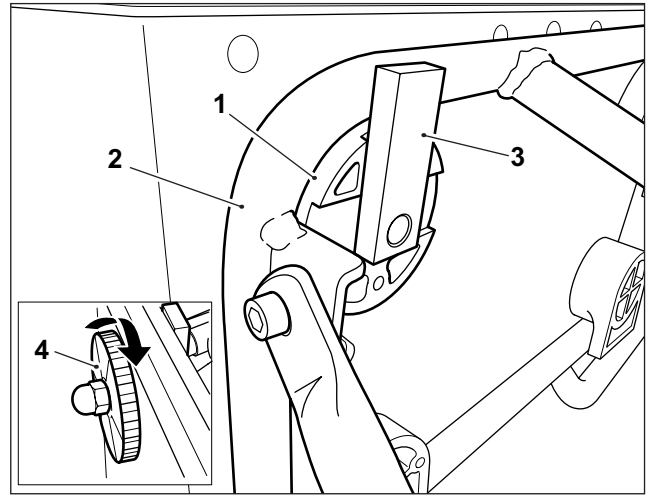

Pannier Operation

5 To open a pannier. Insert the key (1) into the pannier lock and turn the key to the un-locked position, as shown. Remove the key. Lift the lock section (2) of the latch to release the latch (3) from the pannier lid (4).

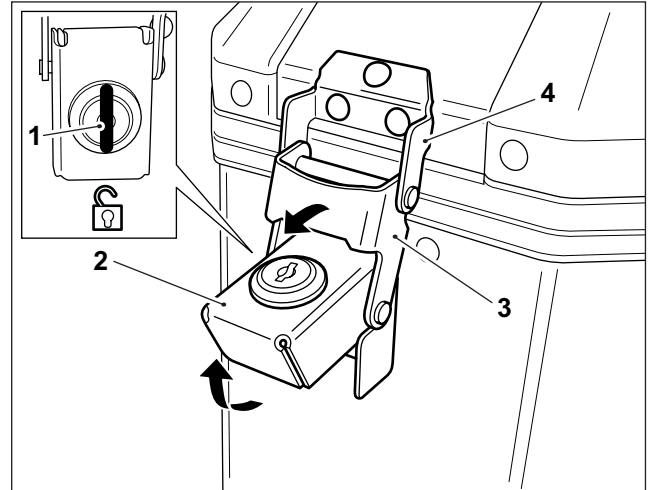

6 To secure a pannier lid in the closed position, ensure the latch (1) is located on the pannier lid (2) and press the lock section (3) of the latch down to secure the pannier lid.

Insert the key (4) into the pannier lock and turn the key to the locked position, as shown. Remove the key.

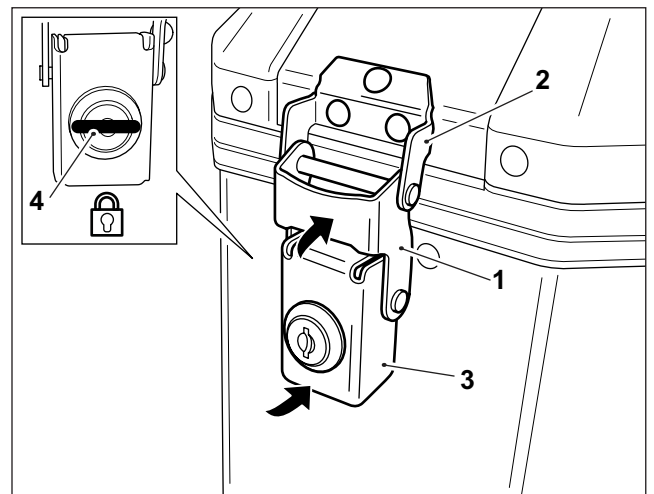

WARNING: Before riding a motorcycle fitted with accessory panniers always check that the panniers are securely attached to the pannier rails. Riding a motorcycle with insecure panniers fitted may cause the motorcycle to become unstable and result in an accident.

WARNING: Panniers must always be fitted to both sides of the motorcycle. Never ride a motorcycle with a pannier fitted to one side of the motorcycle only. Riding a motorcycle with only one pannier fitted may cause the motorcycle to become unstable and result in an accident.

WARNING: Never overload the panniers, the maximum safe load for each pannier is 5 Kg. (11 lbs.). Any load carried should be evenly distributed between both panniers. Incorrect loading of the panniers could cause the motorcycle to become unstable and result in an accident.

WARNING: The fitment of panniers to the motorcycle will affect the stability and handling of the motorcycle. Failure to observe the changes in motorcycle stability and handling characteristics could result in an accident.