

Part Number:
1990674

Models :
Classic 350cc, Classic 500cc
Trials 350cc, Trials 500cc
Bullet 350cc, Bullet 500cc

WARNING: Royal Enfield genuine accessories are designed to fit only the specific Royal Enfield motorcycle(s) that are specified above. They should not be fitted to any other type of motorcycle. Pay particular attention to the warnings and cautions contained in this instruction, failure to do so may result in an incorrect installation of the accessory which could result in an unsafe riding condition and possible accident. If in any doubt always seek the help from your authorised Royal Enfield dealer.

WARNING: Before starting any accessory kit installation ensure the motorcycle is supported in a stable condition. Failure to support the motorcycle correctly could lead to motorcycle damage or personal injury.

WARNING: All fixings must be tightened to the torque values specified in this instruction. Failure to tighten fixings to the correct torque could result in an unsafe riding condition and possible accident.

CAUTION: Care should be taken when fitting any accessory kit. Incorrect handling kit components or the use of incorrect tools could lead to component or motorcycle damage.

NOTE: The content of this instruction is subject to change at any time without notice or liability. Royal Enfield reserves the right to revise the information presented at any time.



Item	Description	Qty
1	Number board	1

1 Insert the ignition key (1) into the lock (2) in the battery cover (3) on the left hand side of the motorcycle.

Turn the key in a quarter turn clockwise direction to release the side panel and carefully pull the bottom of the side panel outwards.

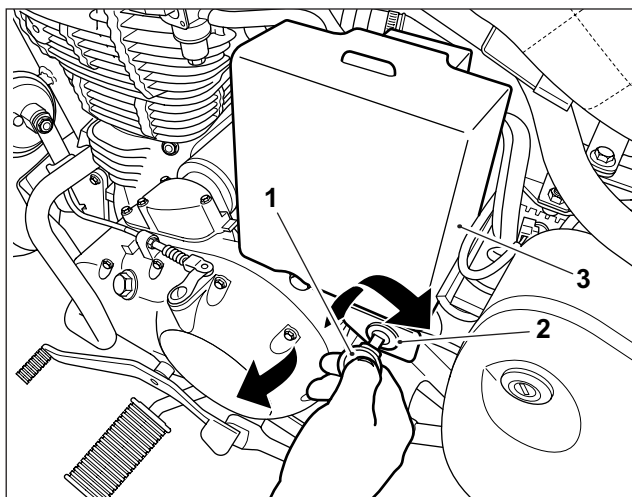

2 Lift the battery cover (1) off the frame location (2) at the top of the side panel. Remove the ignition key from the battery cover lock.

Retain the battery cover for reuse if the accessory number board is removed.

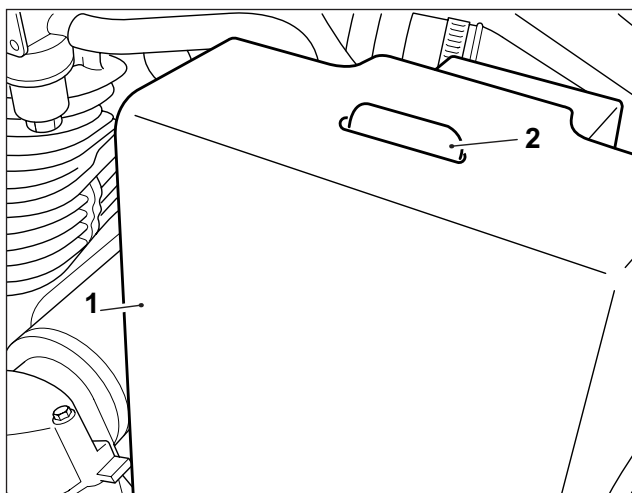

4 Place the side panel (1), painted side down, on a clean soft work surface. Carefully remove the retaining clip (2) securing the side panel lock (3) to the side panel. Remove the side panel lock from the side panel. Retain the side panel lock and retaining clip for reuse.

Retain the side panel for reuse if the accessory number board is removed.

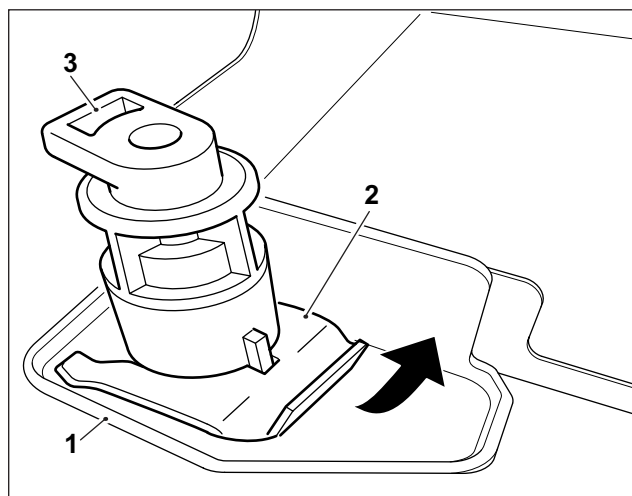

5 Fit the original side panel lock (1) into the accessory number board (2) in the orientation shown. Ensure the raised shoulder (3) on the lock body is aligned correctly with the slot (4) in the number board lock aperture.

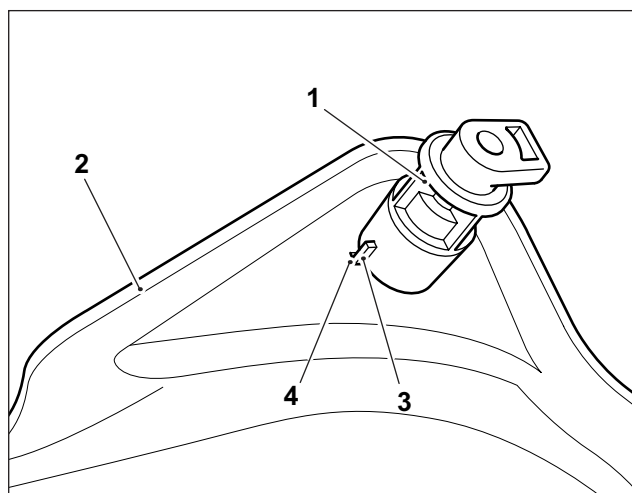

6 Fit the original lock retaining clip (1) to secure the lock (2) to the number board (3), as shown.

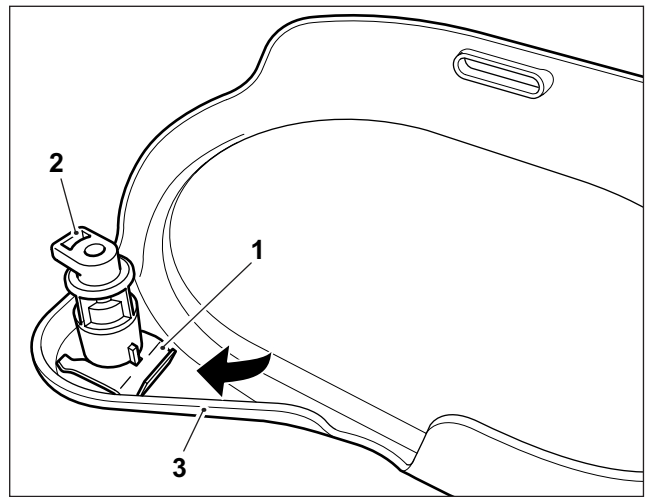

7 Locate the slot (1) at the top of the accessory number board (2) on to the frame location (3) on the left hand side of the motorcycle.

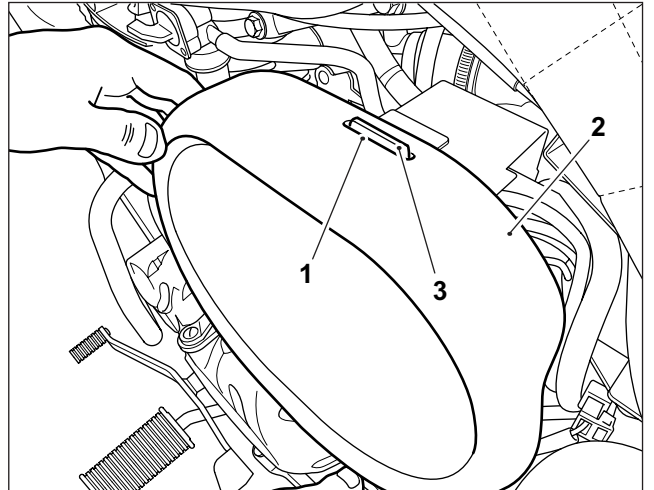

8 Insert the ignition key (1) into the number board lock (2). Push the bottom of the number board (3) in towards the motorcycle frame. Turn the ignition key (1) in a quarter turn anti-clockwise direction to lock the side panel in position. Remove the ignition key.

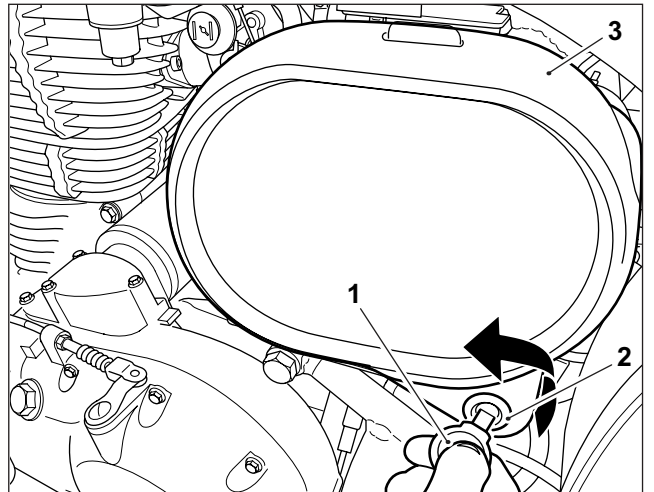

⚠ WARNING: After fitting any genuine Royal Enfield accessory always ride the motorcycle with caution and allow time to become familiar with any change in the motorcycle handling characteristics. Failure to become familiar with any change in the motorcycle handling characteristics may cause the motorcycle to become unstable and result in an accident.