



**Part Number:**  
KXA00247, KXA00331 & KXA00250

**Models:** SUPER METEOR  
SHOTGUN 650  
CLASSIC 650  
BULLET 650

 **WARNING:** Royal Enfield genuine accessories are designed to fit only the specific Royal Enfield motorcycle(s) that are specified above. They should not be fitted to any other type of motorcycle. Pay particular attention to the warnings and cautions contained in this instruction, failure to do so may result in an incorrect installation of the accessory which could result in an unsafe riding condition and possible accident. If in any doubt always seek help from your authorised Royal Enfield dealer.

 **WARNING:** Before starting any accessory kit installation ensure the motorcycle is supported in a stable condition. Failure to support the motorcycle correctly could lead to motorcycle damage or personal injury.

 **WARNING:** All fixings must be tightened to the torque values specified in this instruction. Failure to tighten fixings to the correct torque could result in an unsafe riding condition and possible accident

 **CAUTION:** Care should be taken when fitting any accessory kit. Incorrect handling of kit components or the use of incorrect tools could lead to component or motorcycle damage.

**NOTE:** The content of this instruction is subject to change at any time without notice or liability. Royal Enfield reserves the right to revise the information presented at any time.

**Parts supplied: KXA00247**

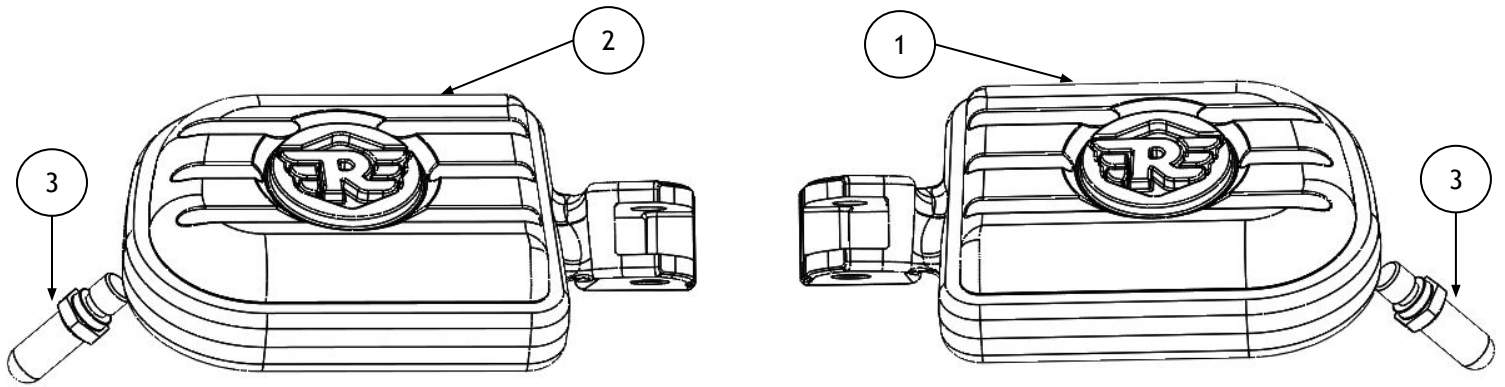

Item	Description	Qty
1	Rider Deluxe footpeg, right hand (Super Meteor)	1
2	Rider Deluxe footpeg, left hand (Super Meteor)	1
3	Footpeg feeler pegs	2

**Parts supplied: KXA00331**

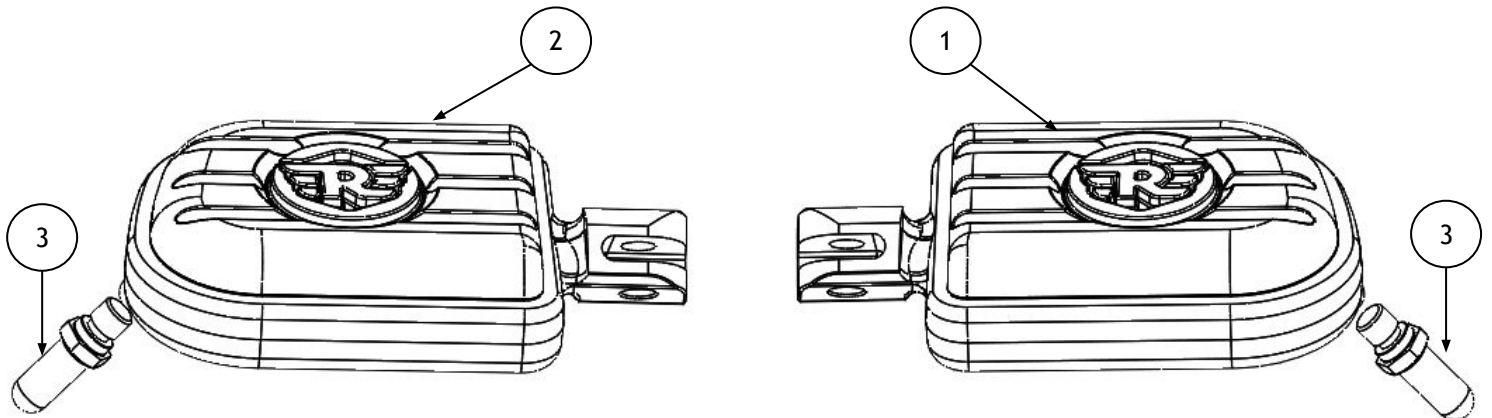

Item	Description	Qty
1	Rider Deluxe footpeg, right hand (Shotgun 650, Classic 650)	1
2	Rider Deluxe footpeg, left hand (Shotgun 650, Classic 650)	1
3	Footpeg feeler pegs	2

**Parts supplied: KXA00250**

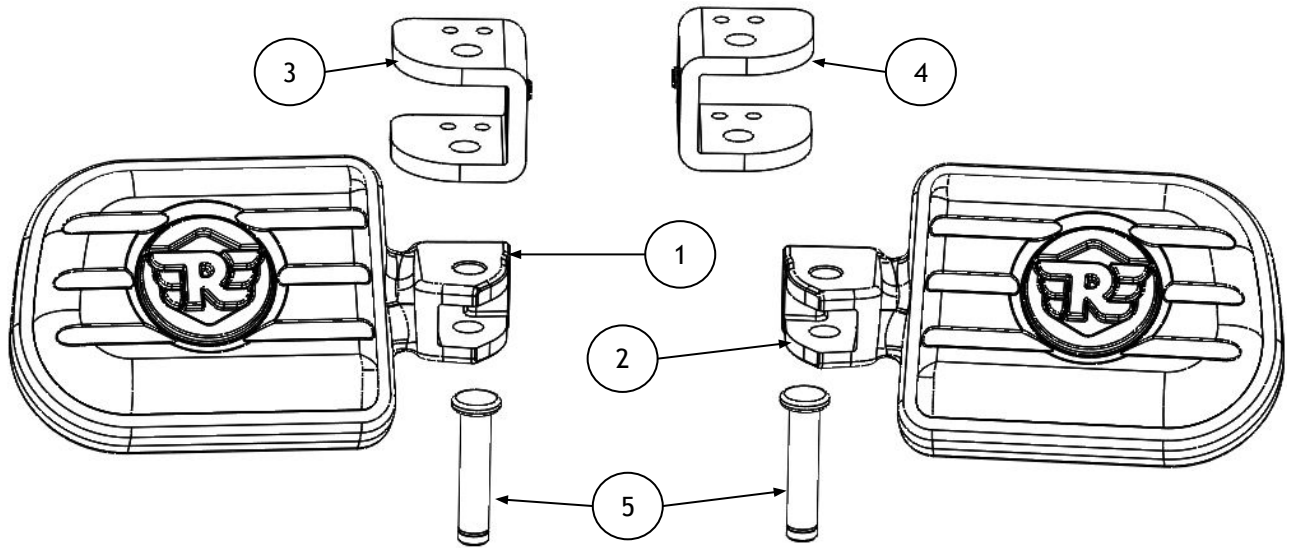

Item	Description	Qty
1	Pillion Deluxe footpeg, Left hand	1
2	Pillion Deluxe footpeg, Right hand	1
3	Clevis plate, Left hand	1
4	Clevis plate, Right hand	1
5	Clevis pin	2

## Rider Footpeg Fitment

**1** Remove the rider footpeg (1) by removing the circlip (2) and the clevis pin (3). Take care when removing the return spring (4).

Retain the clevis pin, the circlip and the return spring for reuse. Retain the footpeg for reuse if the motorcycle is to be returned to its original condition.

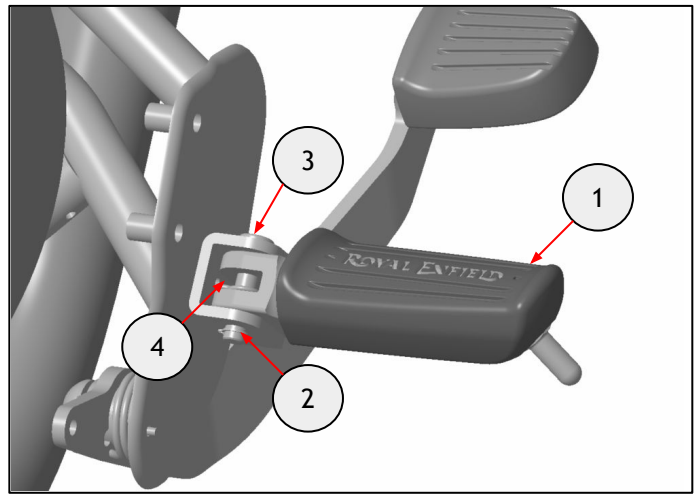

External circlip pliers

**2** Fit the feeler peg (1) from the kit on the footpeg (2)

Tighten the feeler peg (1) to 12 Nm.

**Note:** Super Meteor footpeg represented for visual purpose only. Same step applies for fitment on Shotgun 650.

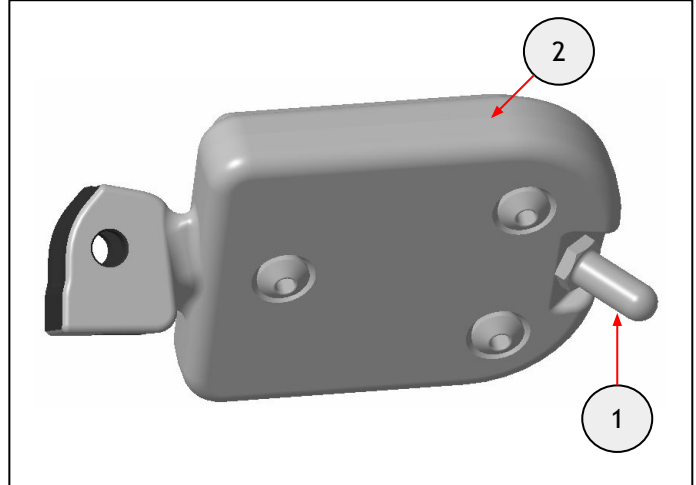

14mm socket and torque wrench

**3** Align the footpeg (1) mounting hole with the clevis (2) hole. Fit the straight end of the return spring (3) in the clevis hole and the other end against the footpeg. Fit the clevis pin (4) through the clevis, the footpeg and the spring.

**Note:** Super Meteor footpeg represented for visual purpose only. Same step applies for fitment on Shotgun 650.

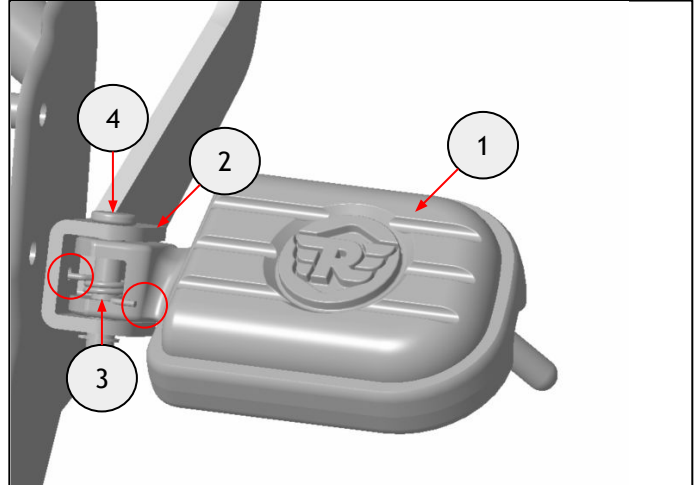

**4** Fit the circlip (1) removed in step 1 into the clevis pin (2) groove.

**Note:** Apply grease on the circlip to avoid rusting.

**Note:** Super Meteor footpeg represented for visual purpose only. Same step applies for fitment on Shotgun 650.

Repeat steps 1 to 4 on the left side.

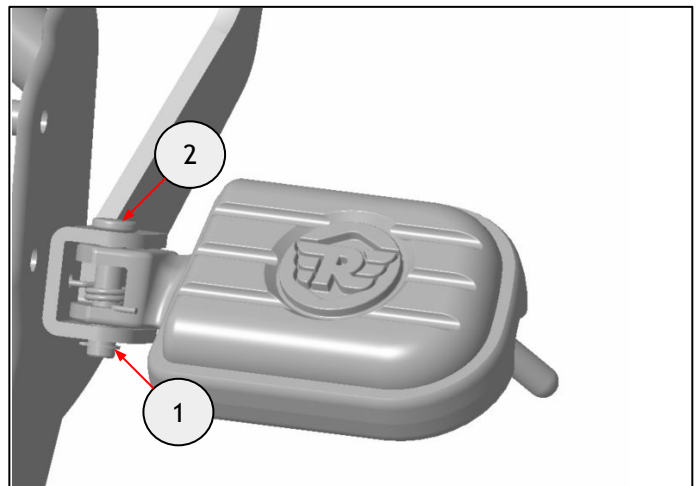

External circlip pliers

## Pillion Footpeg Fitment

**5** Remove the pillion footpeg (1) by removing the circlip (2) and the clevis pin (3). Take care when removing the detent spring (4) and ball bearing (5).

Retain the circlip, the detent spring and the ball bearing for reuse. Retain the clevis pin and the footpeg for reuse if the motorcycle is to be returned to its original condition.

**Note:** Super Meteor footpeg represented for visual purpose only. Same step applies for fitment on Shotgun 650.

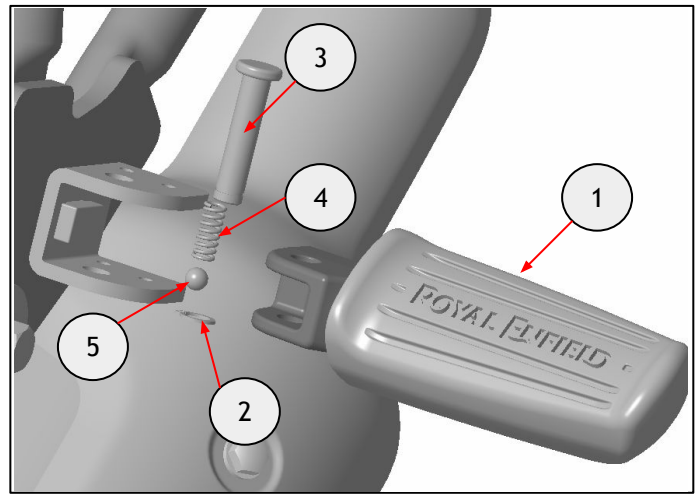

External circlip pliers

**6** Remove the existing clevis plate (1) by removing the fixing (2) and the nut (3).

Retain the fixing and the nut for reuse. Retain the clevis plate for reuse if the motorcycle is to be returned to its original condition.

**Note:** Super Meteor footpeg represented for visual purpose only. Same step applies for fitment on Shotgun 650.

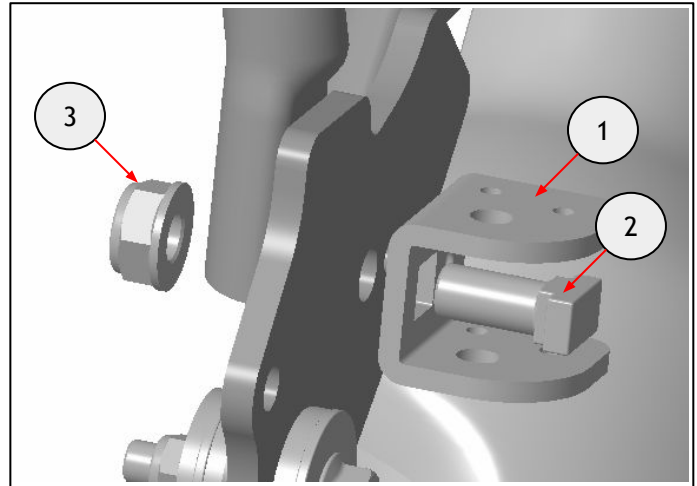

14mm socket and ratchet

**7** Fit the clevis plate (1) from the kit onto the frame using the fixing (2) and the nut (3) removed in step 6. Do not fully tighten at this stage.

**Note:** Ensure the anti rotation feature on the clevis plate aligns with the hole on the frame.

**Note:** Super Meteor footpeg represented for visual purpose only. Same step applies for fitment on Shotgun 650.

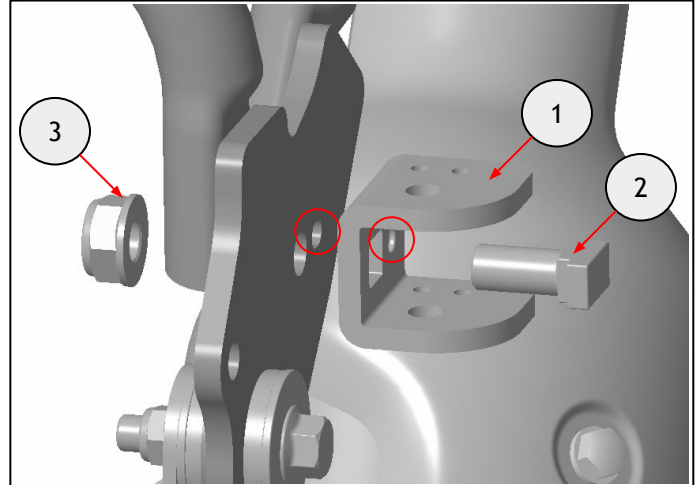

14mm socket and ratchet

**8** Fit the detent spring (1) and the ball bearing (2) removed in step 5 into the dedicated hole on the footpeg (3).

**Note:** Apply grease on the ball bearing to avoid rusting.

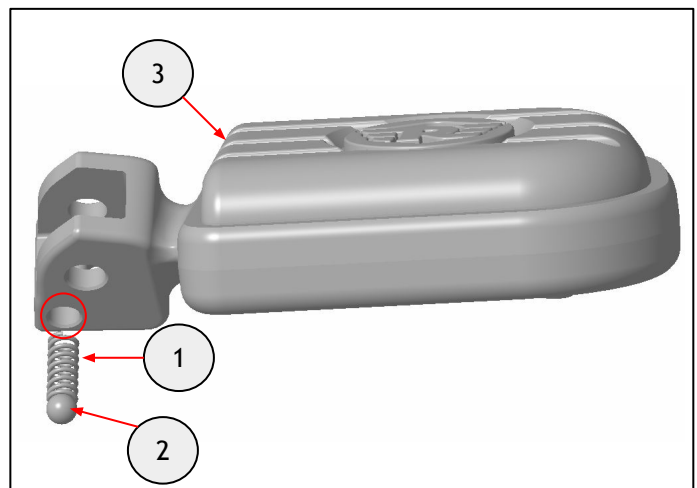

**9** While holding the ball bearing and detent spring in place, align the footpeg (1) mounting hole with the clevis (2) hole. Fit the clevis pin (3) from the kit through the clevis and the footpeg.

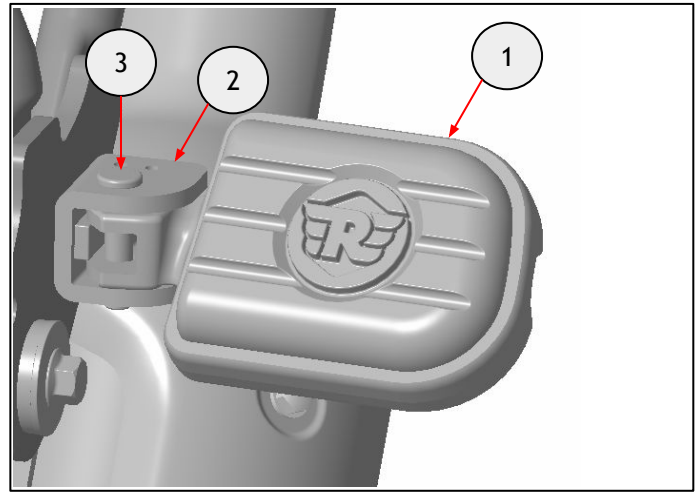

**10** Fit the circlip (1) removed in step 5 into the clevis groove.

**Note:** Apply grease on the circlip to avoid rusting.

Repeat steps 5 to 10 on the left side.

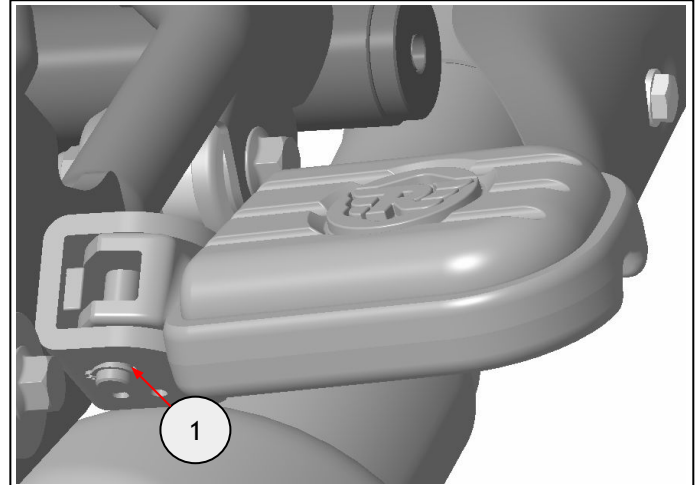

External circlip pliers

**11** Firmly secure the footpeg (1) in a forward rotated position, as shown. Tighten the fixing (2) to 35Nm.

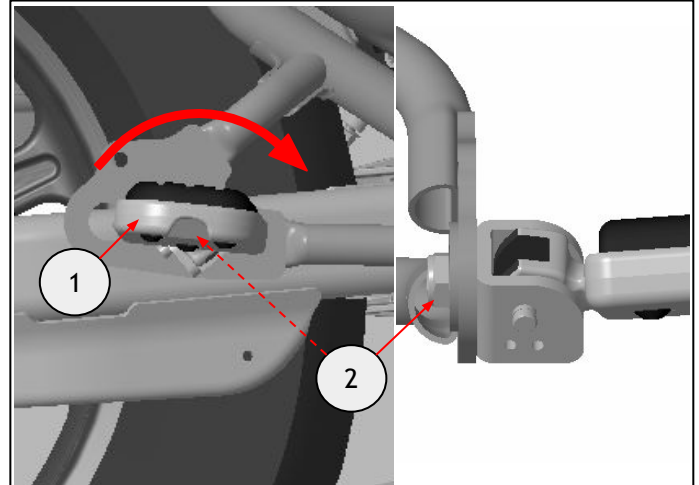

14mm socket and torque wrench

**12** Repeat step 11 on the left side.

**Note:** Ensure the footpegs are cleaned regularly with a non abrasive cleaner.

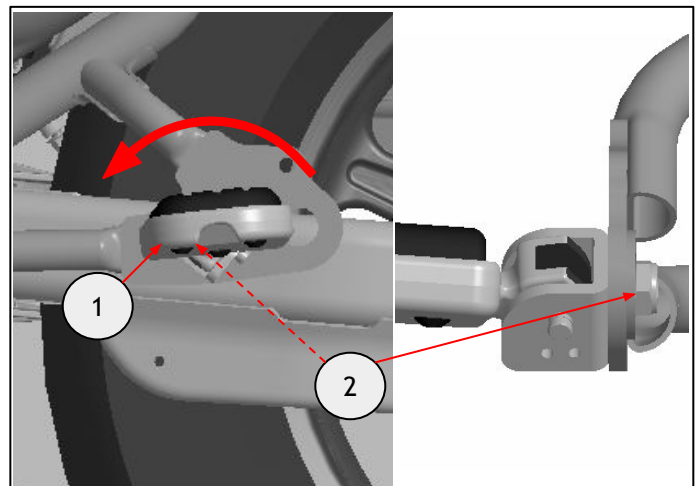



**WARNING:** After fitting any genuine Royal Enfield accessory always ride the motorcycle with caution and allow time to become familiar with any change in the motorcycle handling characteristics. Failure to become familiar with any change in the motorcycle handling characteristics may cause the motorcycle to become unstable and result in an accident.