



**Part Number:**  
KXA00477

**Models:**  
Himalayan (452cc only)

 **WARNING:** Royal Enfield genuine accessories are designed to fit only the specific Royal Enfield motorcycle(s) that are specified above. They should not be fitted to any other type of motorcycle. Pay particular attention to the warnings and cautions contained in this instruction, failure to do so may result in an incorrect installation of the accessory which could result in an unsafe riding condition and possible accident. If in any doubt always seek help from your authorised Royal Enfield dealer.

 **WARNING:** Before starting any accessory kit installation ensure the motorcycle is supported in a stable condition. Failure to support the motorcycle correctly could lead to motorcycle damage or personal injury.

 **WARNING:** All fixings must be tightened to the torque values specified in this instruction. Failure to tighten fixings to the correct torque could result in an unsafe riding condition and possible accident

 **CAUTION:** Care should be taken when fitting any accessory kit. Incorrect handling of kit components or the use of incorrect tools could lead to component or motorcycle damage.

**NOTE:** The content of this instruction is subject to change at any time without notice or liability. Royal Enfield reserves the right to revise the information presented at any time.

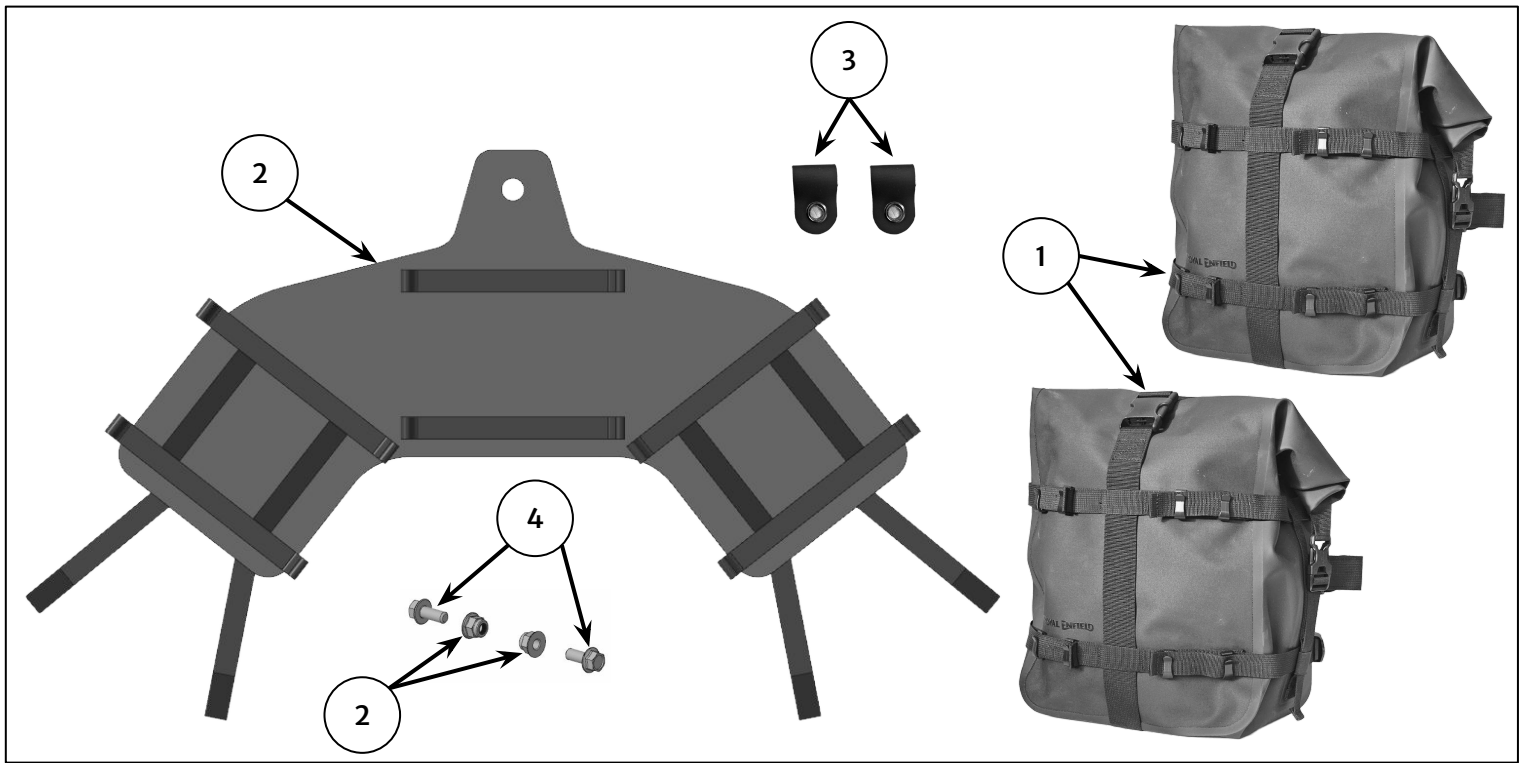

Item	Description	Qty
1	Pannier	2
2	Harness	1
3	Mounting loop	2
4	Fixing, M8 x 20mm	2
5	Nut, M8	2

**WARNING:** The maximum safe load for each bag is 3kg (6.6 lbs). Never exceed this loading limit as this may cause the motorcycle to become unstable and could lead to motorcycle damage or personal injury.

**WARNING:** Always ensure the mounting straps are correctly tensioned before riding the motorcycle. Failure to tighten the straps could result in an unsafe riding condition and possible accident.

**CAUTION:** Use of chemicals or high-pressure spray washers is not recommended for cleaning and may damage the bag. To help maintain its appearance, clean the bag using a sponge or cleaning cloth with low alkaline soap and water.

**1** Place the motorcycle on its centre stand. Collect a mounting loop (1), fixing (2) and nut (3) from the kit and assemble to the right hand pillion footrest (4) as shown.

Do not fully tighten the fixing at this stage.

Repeat step for the left hand side.

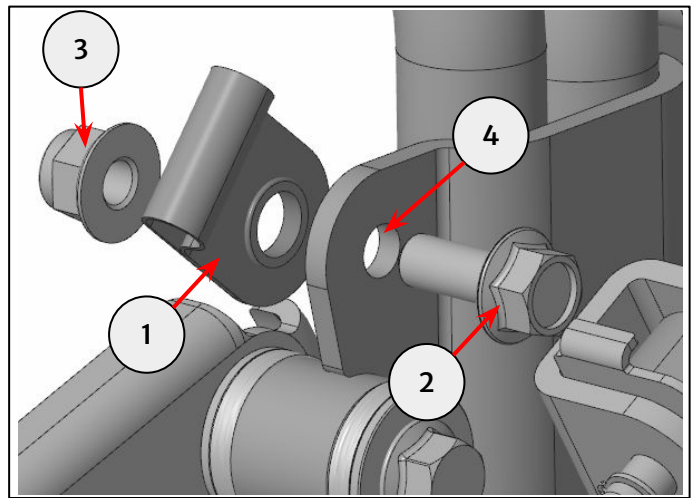

**2** Place the harness over the seat and locate the rear opening (1) over the bobbin (2). Once located, pull the harness forwards.

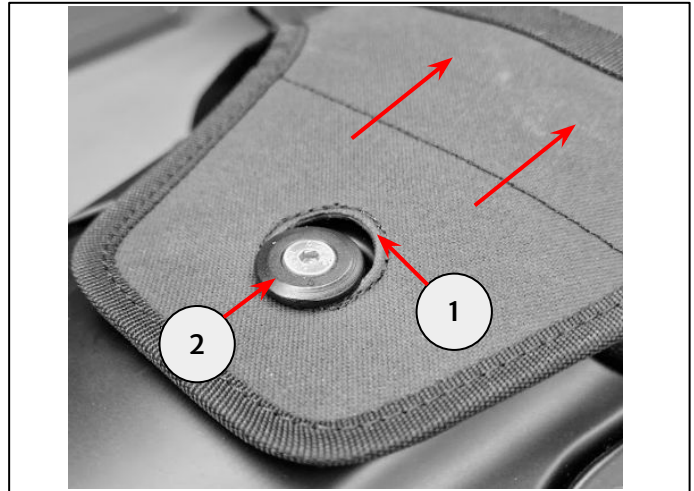

**3** Locate each G hook (1) on the lower strap through the mounting loop on each side (2), tension each strap (3) equally. Secure the excess strap to the harness panel using the velcro attachment (3).

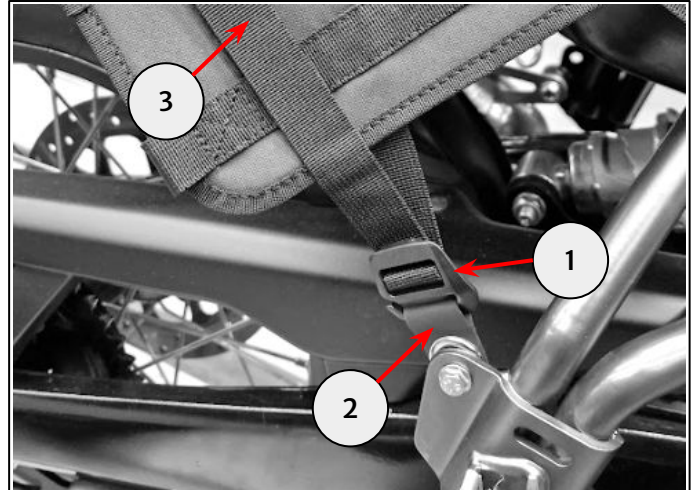

**4** Wrap the upper strap (1) around the frame tube (2) and secure to the harness panel using the velcro attachment (3).

Tighten the fixing (4) through the mounting loop to 20 Nm.

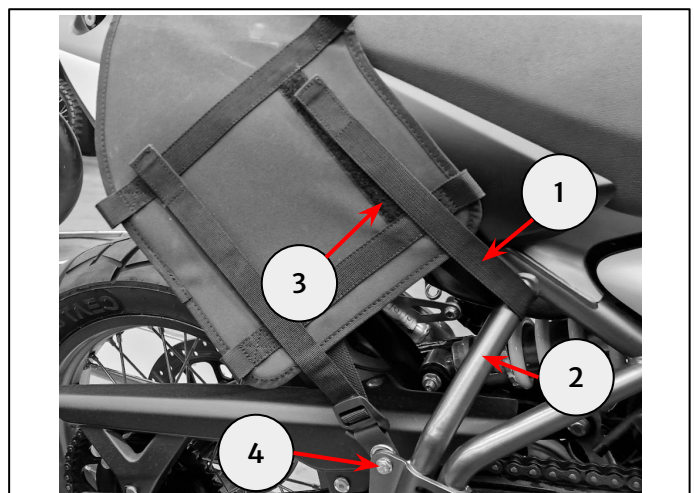

12mm socket and torque wrench  
13mm spanner

**5** Position a pannier to the right hand side of the harness with the opening pointing upwards. Locate each of the four G hooks on the pannier (1) into the webbing loops on the harness (2).

Tension all four straps and secure excess straps using the clips provided (3).

Repeat for the left hand side.

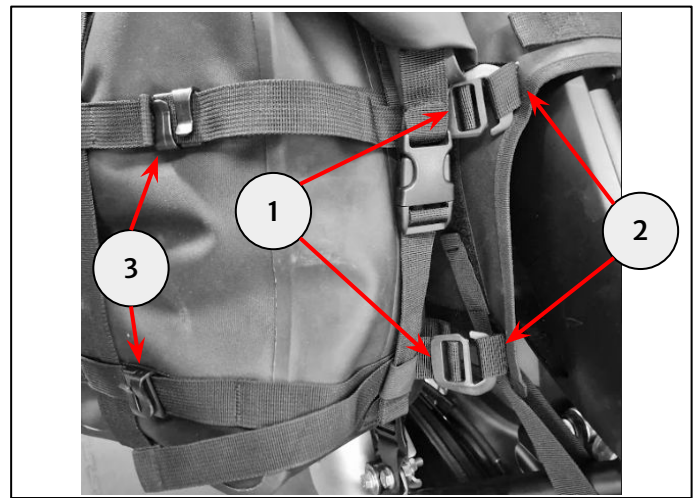

**6** An extra bag - Tail Pack (KXA00442 sold separately) can be mounted to the top side of the harness using the webbing loops provided (1) in addition to the two panniers.

Repeat step 5 for fitment to the harness.



**7** The harness can be removed from the motorcycle along with the bags fitted. Disengage the G hooks from the mounting loops (1) and pull the harness over the bobbin (2).

A handle is provided on the underside of the harness for convenience (3).

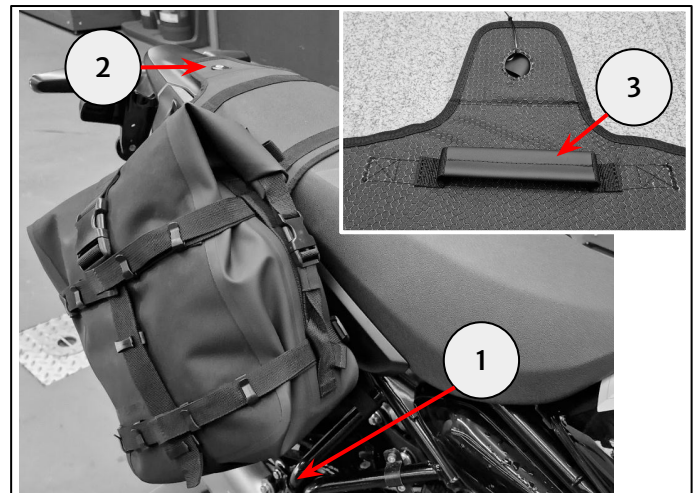

## WARNING:

The maximum safe load for each bag is **3kg (6.6 lbs)**. Never exceed this loading limit as this may cause the motorcycle to become unstable and could lead to motorcycle damage or personal injury.

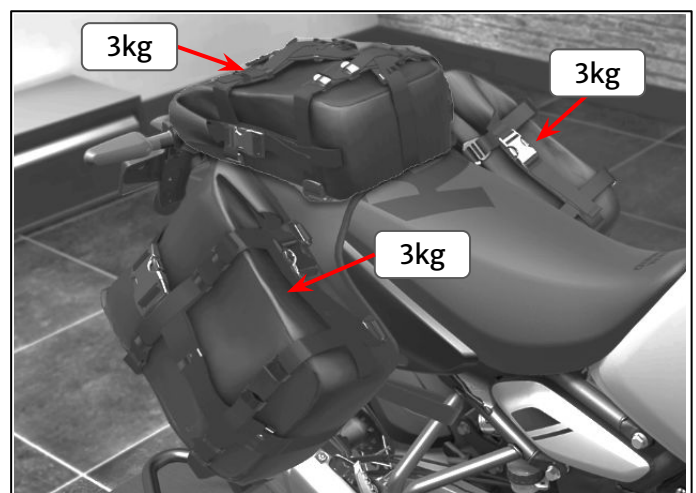

## Pannier Operation

**12** Close the pannier opening (1), ensuring the opening is folded together as shown, and secure using the internal velcro tabs (2).

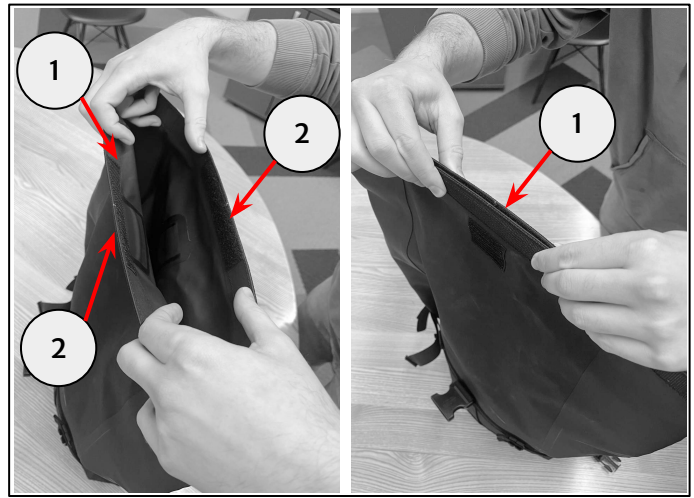

**13** Roll down the opening tightly towards the rear face (1) to take up excess material. Ensure the velcro tabs by the opening (2) and main body (3) are secured together.

Roll tightly a minimum of 3 complete rolls or until secure.

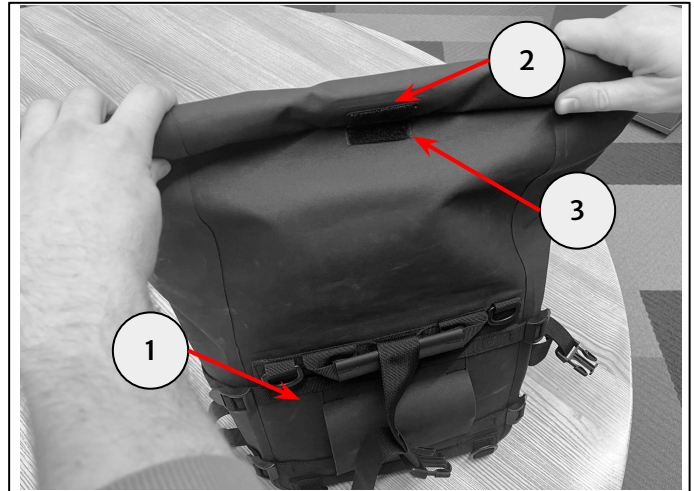

**14** Attach the side clip (1) to the buckle (2) and fully tighten as shown. Repeat for both sides.

Secure excess strap through the elasticated loop provided (3).

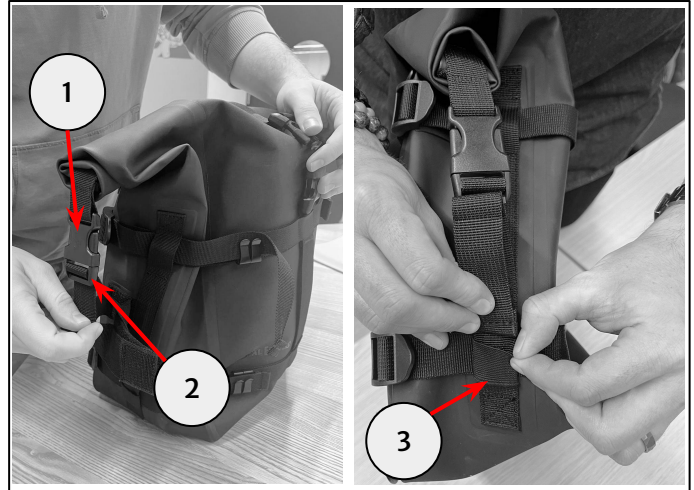

**15** Place the strap (1) over the pannier and secure clip (2) to the buckle (3) as shown.

Fully tighten and secure the excess strap through the elasticated loop provided (4).

