





Part Number:
KXA00289 & KXA00299

Models: SUPER METEOR
SHOTGUN 650

-  **WARNING:** Royal Enfield genuine accessories are designed to fit only the specific Royal Enfield motorcycle(s) that are specified above. They should not be fitted to any other type of motorcycle. Pay particular attention to the warnings and cautions contained in this instruction, failure to do so may result in an incorrect installation of the accessory which could result in an unsafe riding condition and possible accident. If in any doubt always seek help from your authorised Royal Enfield dealer.
-  **WARNING:** Before starting any accessory kit installation ensure the motorcycle is supported in a stable condition. Failure to support the motorcycle correctly could lead to motorcycle damage or personal injury.
-  **WARNING:** All fixings must be tightened to the torque values specified in this instruction. Failure to tighten fixings to the correct torque could result in an unsafe riding condition and possible accident
-  **CAUTION:** Care should be taken when fitting any accessory kit. Incorrect handling of kit components or the use of incorrect tools could lead to component or motorcycle damage.

NOTE: The content of this instruction is subject to change at any time without notice or liability. Royal Enfield reserves the right to revise the information presented at any time.

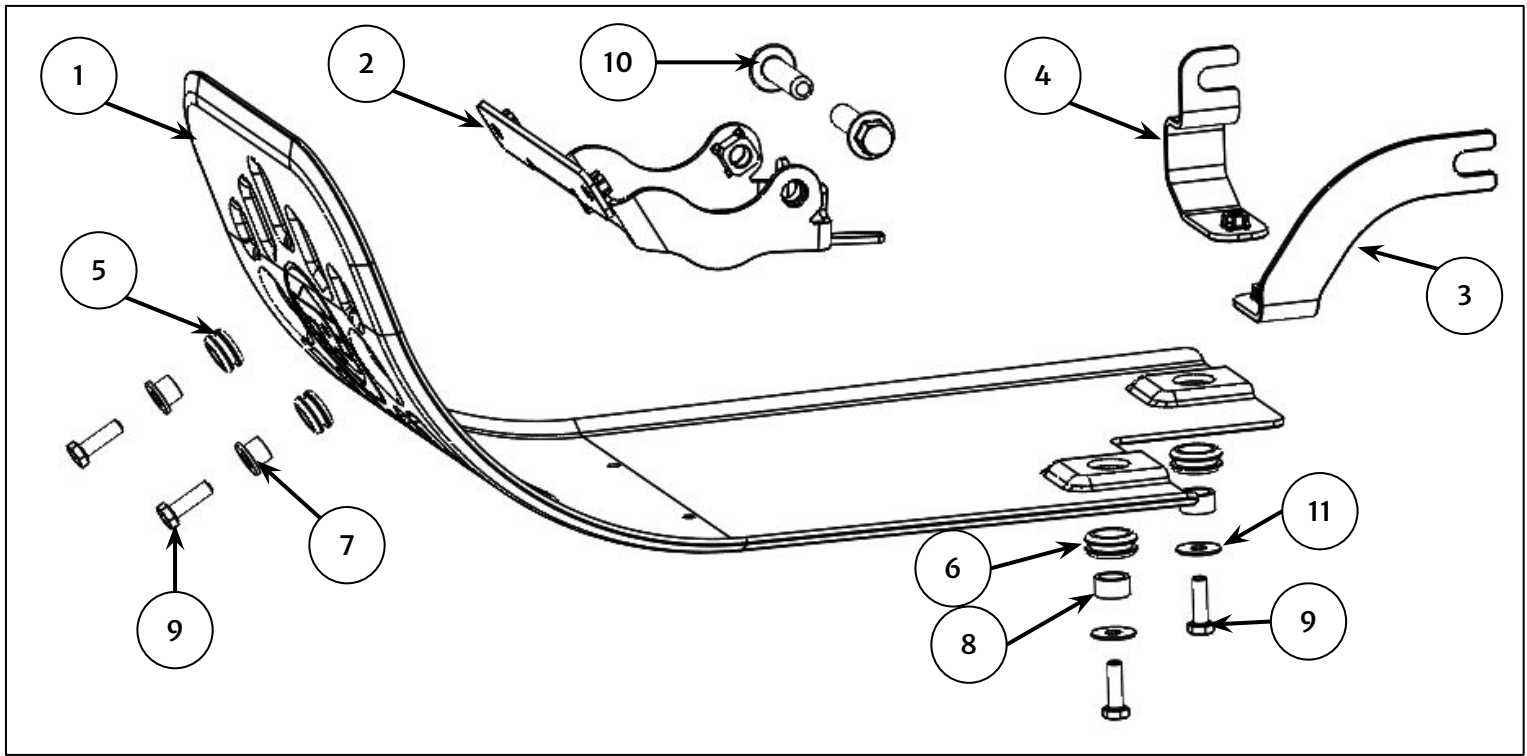

| Item | Description | Qty |
|------|--------------------------|-----|
| 1 | Sump guard | 1 |
| 2 | Front bracket | 1 |
| 3 | Rear bracket, left hand | 1 |
| 4 | Rear bracket, right hand | 1 |
| 5 | Rubber grommet, M6 | 2 |
| 6 | Rubber grommet, M10 | 2 |
| 7 | Flanged inserts | 2 |
| 8 | Spacer boss, 15 x 8 mm | 2 |
| 9 | Fixing, M6 x 20 mm | 4 |
| 10 | Fixing, M10 x 40 mm | 2 |
| 11 | Washer, 19 x 1mm | 2 |

1 Fit the M6 rubber grommets (1) into the sump guard (2).
Fit the flanged insert (3) into the rubber grommet.

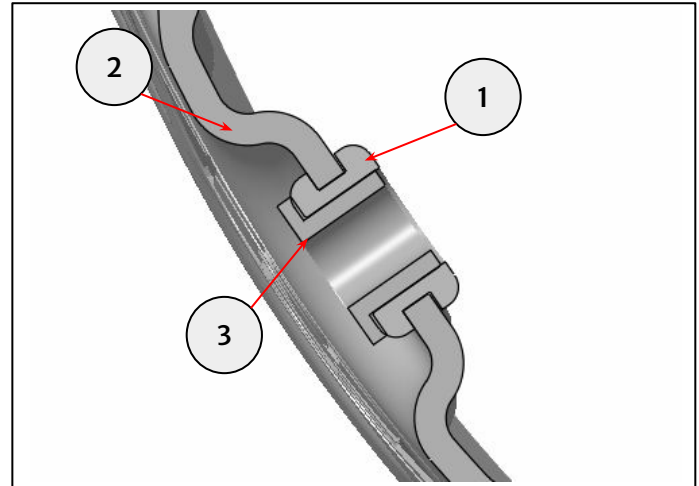
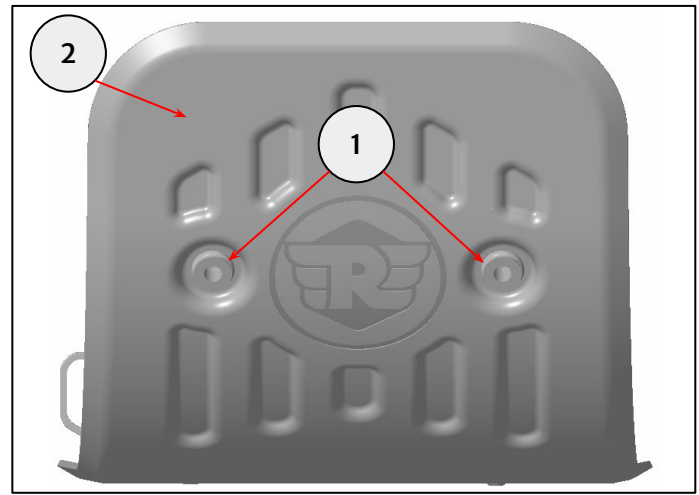

2 Fit the M10 rubber grommets (1) into the sump guard (2).
Fit the 15 x 8 mm spacers (3) into the rear rubber grommets.

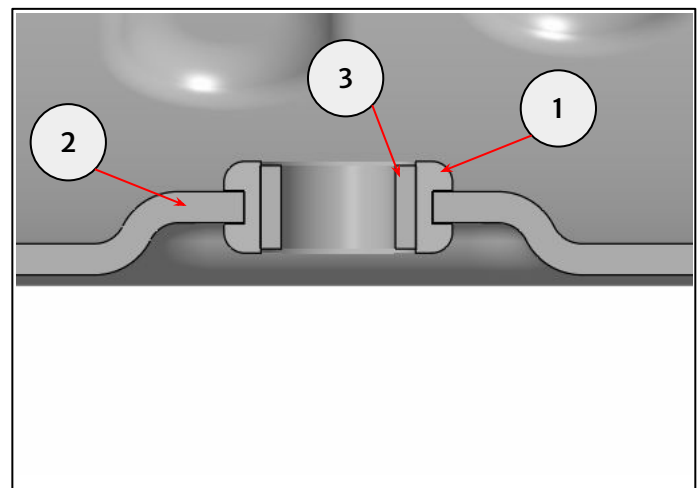
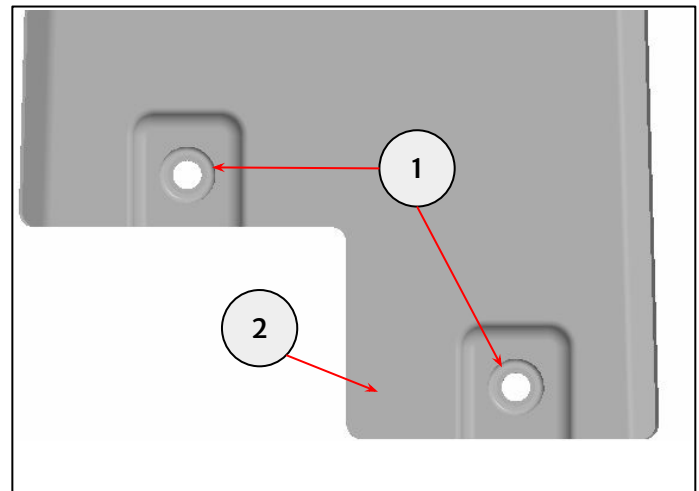

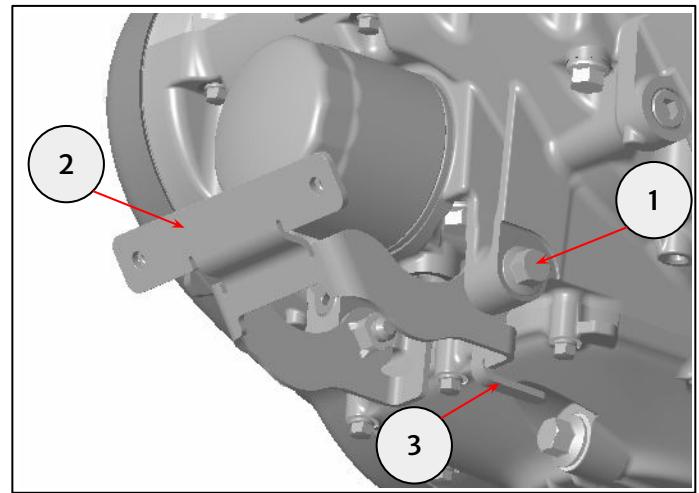

3 Fit the M10 x 40 mm fixing (1) from the kit to secure the front bracket (2). Ensure there is a contact between the anti rotation tab (3) and the engine. Tighten the fixings to **45Nm**.

| | |
|--|-------------------------------|
|  | 13mm socket and torque wrench |
|--|-------------------------------|



4 Loosen the engine lower fixing (1).

| | |
|--|-------------------------|
|  | 14mm socket and ratchet |
|--|-------------------------|

| | |
|--|--------------|
|  | 14mm spanner |
|--|--------------|

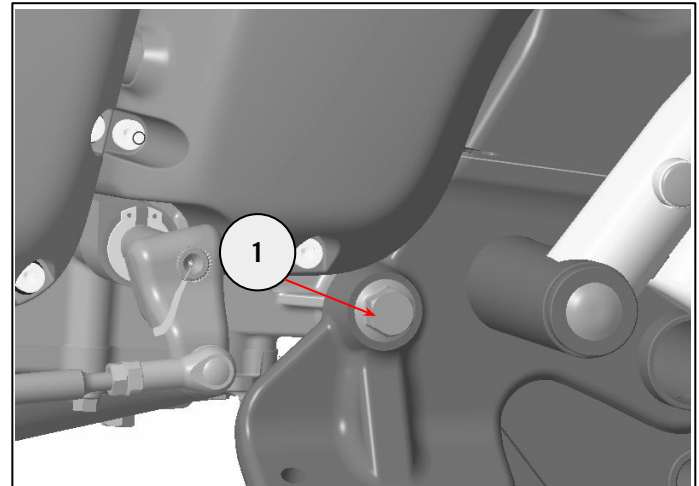

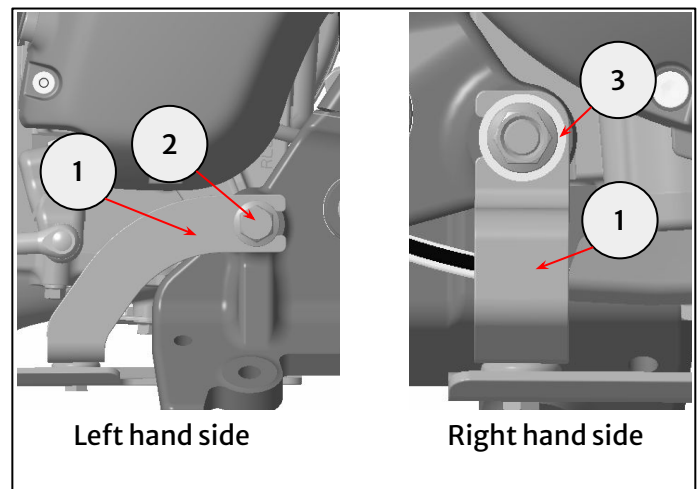

5 Slide the rear brackets (1) between the lower engine mount and the fixing (2) on the left hand side and between the lower engine mount and the washer (3) on the right hand side.



6 Fit the sump guard (1) on the brackets using the M6 x 20 mm fixings from the kit (2) with a 19 x 1 mm washer (3) from the kit under the lower fixings. Tighten the fixings (3) to **10Nm**. Tighten the fixings from step 5 to **45Nm**.

| | |
|--|-------------------------------|
|  | 10mm socket and torque wrench |
|--|-------------------------------|

| | |
|--|-------------------------------|
|  | 14mm socket and torque wrench |
|--|-------------------------------|

| | |
|--|--------------|
|  | 14mm spanner |
|--|--------------|

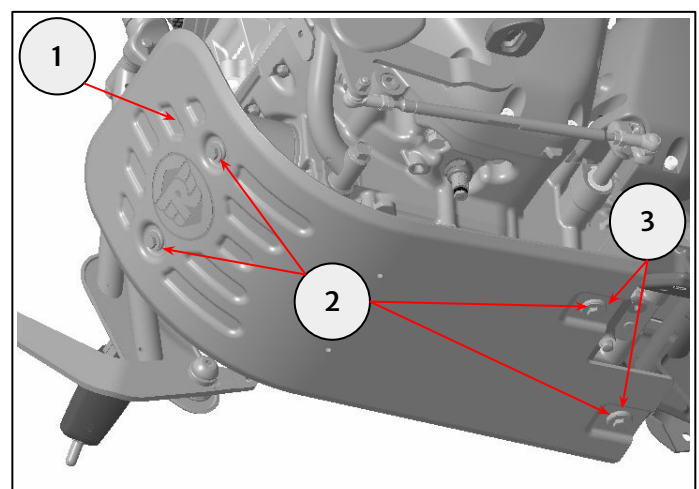



WARNING: After fitting any genuine Royal Enfield accessory always ride the motorcycle with caution and allow time to become familiar with any change in the motorcycle handling characteristics. Failure to become familiar with any change in the motorcycle handling characteristics may cause the motorcycle to become unstable and result in an accident.