

**Part Number:**

1990615

1990616

**Models:**

Bullet 350cc, Bullet 500cc

Classic 350cc, Classic 500cc

Electra 350cc

Thunderbird 350cc, Thunderbird 500cc

Thunderbird X 350cc, Thunderbird X 500cc

 **WARNING:** Royal Enfield genuine accessories are designed to fit only the specific Royal Enfield motorcycle(s) that are specified above. They should not be fitted to any other type of motorcycle. Pay particular attention to the warnings and cautions contained in this instruction, failure to do so may result in an incorrect installation of the accessory which could result in an unsafe riding condition and possible accident. If in any doubt always seek the help from your authorised Royal Enfield dealer.

 **WARNING:** Before starting any accessory kit installation ensure the motorcycle is supported in a stable condition. Failure to support the motorcycle correctly could lead to motorcycle damage or personal injury.

 **WARNING:** All fixings must be tightened to the torque values specified in this instruction. Failure to tighten fixings to the correct torque could result in an unsafe riding condition and possible accident.

 **CAUTION:** Care should be taken when fitting any accessory kit. Incorrect handling kit components or the use of incorrect tools could lead to component or motorcycle damage.

**NOTE:** The content of this instruction is subject to change at any time without notice or liability. Royal Enfield reserves the right to revise the information presented at any time.

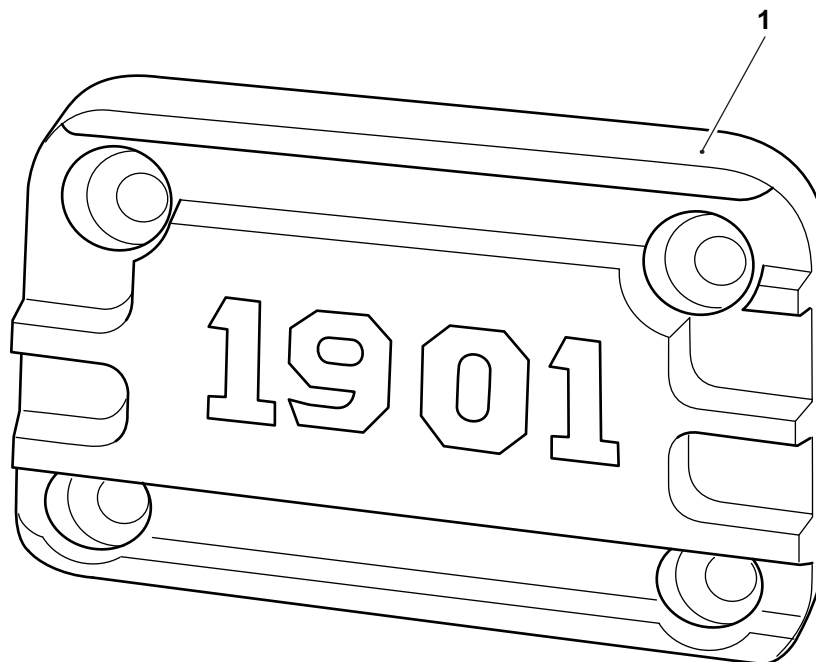

Item	Description	Qty
1	Tappet cover	1

**WARNING:** If the engine has recently been running the engine and exhaust system will be hot. Before working near to the engine or exhaust system always allow time for the engine and exhaust system to cool. Touching any part of a hot engine or exhaust system will cause burn injuries.

**NOTE:** Ensure a catch tray or cloth is placed under the tappet cover (1) to prevent any oil running on to the motorcycle engine or exhaust system when the tappet cover is removed.

**1** Remove the four fixings (1) securing the tappet cover (2) and carefully remove the tappet cover. Retain the original tappet cover for reuse if the accessory tappet cover is removed. Retain the four fixings for reuse.

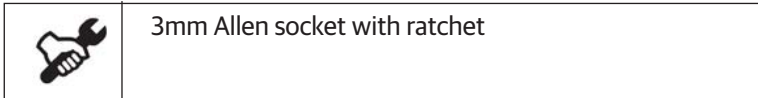
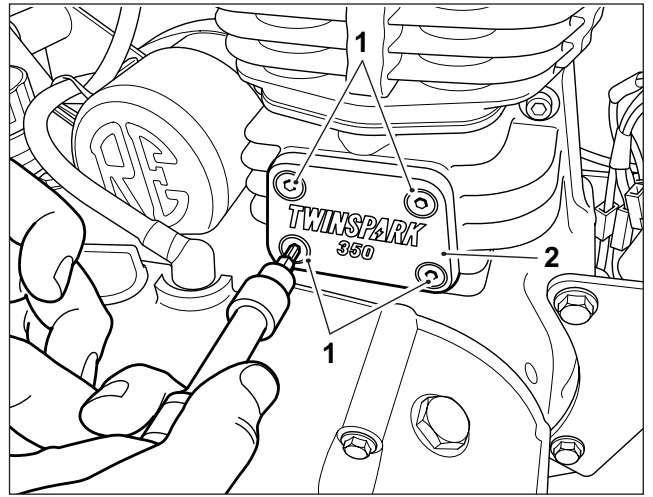

**2** Clean the tappet cover mounting area (1) on the engine removing any residue gasket sealant, debris or corrosion. Care should be taken to ensure residue gasket sealant or debris are not allowed to enter the tappet cover aperture in the engine during the cleaning operation.

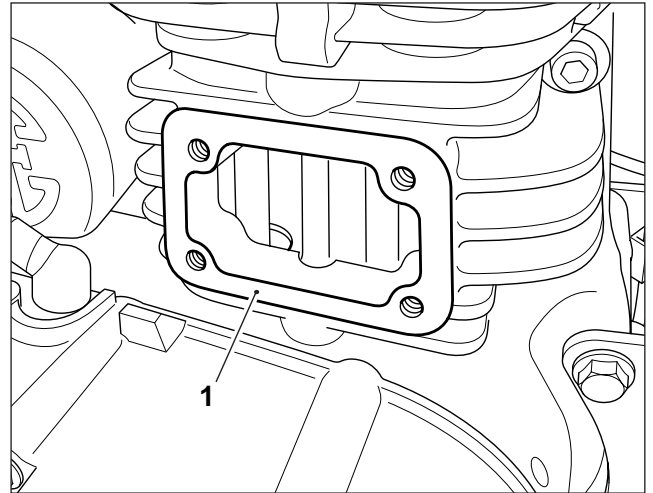

**3** Collect the accessory tappet cover (1) from the kit and apply a 1.5g bead of Anabond 666T Plus or equivalent gasket sealant (2) to the rear of the tappet cover in the area shown.

**NOTE:** The Anabond 666T Plus or equivalent gasket sealant is available from your local Royal Enfield Service Centre.

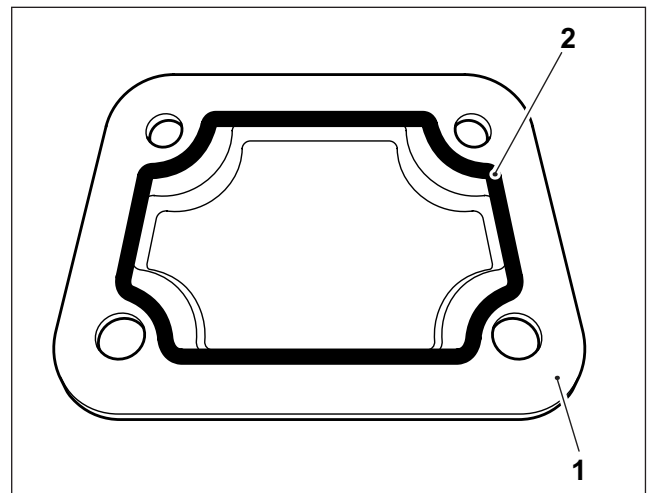

**4** Fit the accessory tappet cover (1) to the engine and secure with the original four fixings (2). Tighten the fixings to **6Nm**. If necessary, wipe off any excess gasket sealant from around the tappet cover.

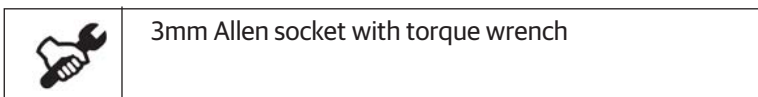

**WARNING:** After fitting any genuine Royal Enfield accessory always ride the motorcycle with caution and allow time to become familiar with any change in the motorcycle handling characteristics. Failure to become familiar with any change in the motorcycle handling characteristics may cause the motorcycle to become unstable and result in an accident.

